

50Hz SUBMERSIBLE MOTORS

APPLICATION • INSTALLATION • MAINTENANCE



Commitment To Quality

Franklin Electric is committed to provide customers with defect free products through our program of continuous improvement. Quality shall, in every case, take precedence over quantity.



Franklin Electric

www.franklin-electric.com



Submersible Motors

Application • Installation • Maintenance Manual

The submersible motor is a reliable, efficient and trouble-free means of powering a pump. Its needs for a long operational life are simple. They are:

1. A suitable operating environment
2. An adequate supply of electricity
3. An adequate flow of cooling water over the motor
4. An appropriate pump load

All considerations of application, installation, and maintenance of submersible motors relate to these four areas. This manual will acquaint you with these needs and assist you if service or maintenance is required.

Application - All Motors

Storage	3
Frequency of Starts	3
Mounting Position.....	3
Transformer Capacity.....	4
Effects of Torque.....	4
Engine Driven Generators.....	5
Use of Check Valves	5
Well Diameters, Casing, Top Feeding, Screens.....	6
Water Temperature and Flow	6
Flow Inducer Sleeve.....	6
Head Loss Past Motor	7
Hot Water Applications	7-8
Drawdown Seals.....	9
Grounding Control Boxes and Panels	9
Grounding Surge Arrestors	9
Control Box and Panel Environment	9

Application - Single-Phase Motors

3-Wire Control Boxes	10
2-Wire Motor Solid State Controls	10
Cable Selection - 2-Wire or 3-Wire	11
Two Different Cable Sizes	12
Single-Phase Motor Specifications	13

Application - Three-Phase Motors

Cable Selection - 70°C 3 or 6 Lead	14
Cable Selection - 75°C 3 or 6 Lead	15
Three-Phase Motor Specifications	16-18
Overload Protection	19
Submonitor Three-Phase Protection	20
Power Factor Correction	20
Three-Phase Starter Diagrams	21
Three-Phase Power Unbalance	22
Rotation and Current Unbalance.....	22
Submersible Pump Installation Check List (No.3656)	
Submersible Motor Installation Record (No. 2207)	

Submersible Booster Installation Record (No. 3655)	
Three-Phase Motor Lead Identification	23
Reduced Voltage Starters	24
Inline Booster Pump Systems.....	24-27
Variable Speed Operation.....	28

Installation - All Motors

Submersible Motors - Dimensions	29
Tightening Lead Connector Jam Nut	30
Pump to Motor Coupling	30
Shaft Height and Free End Play	30
Submersible Leads and Cables.....	30
Splicing Submersible Cables.....	31
Heat Shrink Splicing	31

Maintenance - All Motors

System Troubleshooting	32-33
Preliminary Tests	34
Insulation Resistance	35
Resistance of Drop Cable.....	35

Maintenance - Single-Phase Motors & Controls

Identification of Cables	36
Single-Phase Control Boxes.....	36
Ohmmeter Tests.....	37
QD Control Box Parts	38
Integral HP Control Box Parts.....	38
Control Box Wiring Diagrams	39-40

Maintenance - Electronic Products

Pumptec Troubleshooting	41
Pumptec-Plus Troubleshooting During Installation	42
Pumptec-Plus Troubleshooting After Installation	43
CP Water Troubleshooting.....	44
Submonitor Troubleshooting.....	45
Subtrol-Plus Troubleshooting	46-47



Application - All Motors

Storage

Franklin Electric submersible motors are a water-lubricated design. The fill solution consists of a mixture of de-ionized water and Propylene Glycol (a non-toxic antifreeze). The solution will prevent damage from freezing in temperatures to -40°C; motors should be stored in areas that do not go below this temperature. The solution will partially freeze below -3°C, but no damage occurs. Repeated freezing and thawing should be avoided to prevent possible loss of fill solution.

There may be an interchange of fill solution with well water during operation. Care must be taken with motors removed from wells during freezing conditions to prevent damage.

When the storage temperature does not exceed 37°C, storage time should be limited to two years. Where temperatures reach 37° to 54°C, storage time should be limited to one year.

Loss of a few drops of liquid will not damage the motor as an excess amount is provided, and the filter check valve will allow lost liquid to be replaced by filtered well water upon installation. If there is reason to believe there has been a considerable amount of leakage, consult the factory for checking procedures.

Frequency of Starts

The average number of starts per day over a period of months or years influences the life of a submersible pumping system. Excessive cycling affects the life of control components such as pressure switches, starters, relays and capacitors. Rapid cycling can also cause motor spline damage, bearing damage, and motor overheating. All these conditions can lead to reduced motor life.

The pump size, tank size and other controls should be selected to keep the starts per day as low as practical for longest life. The maximum number of starts per 24-hour period is shown in Table 1.

Motors should run a minimum of one minute to dissipate heat build up from starting current. Six inch and larger motors should have a minimum of 15 minutes between starts or starting attempts.

Table 1 Number of Starts

Motor Rating		Maximum Starts Per 24 hr Period	
HP	KW	Single-Phase	Three-Phase
Up to 0.75	Up to 0.55	300	300
1 thru 5.5	0.75 thru 4	100	300
7.5 thru 30	5.5 thru 22	50	100*
40 and over	30 and over	-	100

* Keeping starts per day within the recommended numbers provides the best system life. However, when used with a properly configured Reduced Voltage Starter (RVS) or Variable Frequency Drive (VFD), 7.5 thru 30 hp three-phase motors can be started up to 200 times per 24 hour period.

Mounting Position

Franklin submersible motors are designed primarily for operation in the vertical, shaft-up position.

During acceleration, the pump thrust increases as its output head increases. In cases where the pump head stays below its normal operating range during startup and full speed condition, the pump may create upward thrust. This creates upward thrust on the motor upthrust bearing. This is an acceptable operation for short periods at each start, but running continuously with upthrust will cause excessive wear on the upthrust bearing.

With certain additional restrictions as listed in this section and the Inline Booster Pump Systems sections of this manual, motors are also suitable for operation

in positions from shaft-up to shaft-horizontal. As the mounting position becomes further from vertical and closer to horizontal, the probability of shortened thrust bearing life increases. For normal motor life expectancy with motor positions other than shaft-up, follow these recommendations:

1. Minimize the frequency of starts, preferably to fewer than 10 per 24-hour period. Six and eight inch motors should have a minimum of 20 minutes between starts or starting attempts
2. Do not use in systems which can run even for short periods at full speed without thrust toward the motor.



Application - All Motors

Transformer Capacity - Single-Phase or Three-Phase

Distribution transformers must be adequately sized to satisfy the KVA requirements of the submersible motor. When transformers are too small to supply the load, there is a reduction in voltage to the motor.

Table 2 references the motor horsepower rating, single-phase and three-phase, total effective KVA required,

and the smallest transformer required for open or closed three-phase systems. Open systems require larger transformers since only two transformers are used.

Other loads would add directly to the KVA sizing requirements of the transformer bank.

TABLE 2 Transformer Capacity

Motor Rating		Total Effective KVA Required	Smallest KVA Rating-Each Transformer	
HP	KW		Open WYE or DELTA 2-Transformers	Closed WYE or DELTA 3-Transformers
1.5	1.1	3	2	1
2	1.5	4	2	1.5
3	2.2	5	3	2
5	3.7	7.5	5	3
7.5	5.5	10	7.5	5
10	7.5	15	10	5
15	11	20	15	7.5
20	15	25	15	10
25	18.5	30	20	10
30	22	40	25	15
40	30	50	30	20
50	37	60	35	20
60	45	75	40	25
75	55	90	50	30
100	75	120	65	40
125	90	150	85	50
150	110	175	100	60
175	130	200	115	70
200	150	230	130	75

NOTE: Standard KVA ratings are shown. If power company experience and practice allows transformer loading higher than standard, higher loading values may be used for transformer(s) to meet total effective KVA required, provided correct voltage and balance is maintained.

Effects of Torque

During starting of a submersible pump, the torque developed by the motor must be supported through the pump, delivery pipe or other supports. Most pumps rotate in the direction which causes unscrewing torque on right-handed threaded pipe or pump stages. All threaded joints, pumps and other parts of the pump support system must be capable of withstanding the maximum torque repeatedly without loosening or breaking. Unscrewing joints will break electrical cable and may cause loss of the pump-motor unit.

To safely withstand maximum unscrewing torques with a minimum safety factor of 1.5, tightening all threaded joints to at least 13.57 N-m per motor horsepower is recommended (Table 2A). It may be necessary to tack or strap weld pipe joints on high horsepower pumps, especially at shallower settings.

TABLE 2A Torque Required (Examples)

Motor Rating		HP x 13.57 N-m	Minimum Safe Torque-Load
HP	KW		
1 HP & Less	.75 KW & Less	1 X 13.57	13.57 N-m
20 HP	15 KW	20 X 13.57	271.4 N-m
75 HP	55 KW	75 x 13.57	1017.8 N-m
200 HP	150 KW	200 x 13.57	2714 N-m



Application - All Motors

Engine Driven Generators

Refer to generator manufacturer's recommendations and locked rotor amps listed on page 13 (single-phase) and pages 16-18 (three-phase).

Use of Check Valves

It is recommended that one or more check valves always be used in submersible pump installations. If the pump does not have a built-in check valve, a line check valve should be installed in the discharge line within 7.6 m (25 feet) of the pump and below the draw down level of the water supply. For deeper settings, check valves should be installed per the manufacturer's recommendations. More than one check valve may be required, but more than the recommended number of check valves should not be used.

Swing type check valves are not acceptable and should never be used with submersible motors/pumps. Swing type check valves have a slower reaction time which can cause water hammer (see next page). Internal pump check valves or spring loaded check valves close quickly and help eliminate water hammer.

Check valves are used to hold pressure in the system when the pump stops. They also prevent backspin, water hammer and upthrust. Any of these can lead to early pump or motor failure.

NOTE: Only positive sealing check valves should be used in submersible installations. Although drilling the check valves or using drain-back check valves may prevent back spinning, they create upthrust and water hammer problems.

A. Backspin - With no check valve or a failed check valve, the water in the drop pipe and the water in the system can flow down the discharge pipe when the motor stops. This can cause the pump to rotate in a reverse direction. If the motor is started while it is backspinning, an excessive force is placed across the pump-motor assembly that can cause impeller damage, motor or pump shaft breakage, excessive bearing wear, etc.

- B. Upthrust** - With no check valve, a leaking check valve, or drilled check valve, the unit starts under a zero head condition. This causes an uplifting or upthrust on the impeller-shaft assembly in the pump. This upward movement carries across the pump-motor coupling and creates an upthrust condition in the motor. Repeated upthrust can cause premature failure of both the pump and the motor.
- C. Water Hammer** - If the lowest check valve is more than 9.1 m (30 feet) above the standing (lowest static) water level, or a lower check valve leaks and the check valve above holds, a vacuum is created in the discharge piping. On the next pump start, water moving at very high velocity fills the void and strikes the closed check valve and the stationary water in the pipe above it, causing a hydraulic shock. This shock can split pipes, break joints and damage the pump and/or motor. Water hammer can often be heard or felt. When discovered, the system should be shut down and the pump installer contacted to correct the problem.



Application - All Motors

Wells-Large Diameter, Uncased, Top Feeding & Screened Sections

Franklin Electric submersible motors are designed to operate with a cooling flow of water over the motor.

If the pump installation does not provide the minimum flow shown in Table 3, a flow inducer sleeve (flow sleeve) must be used. The conditions requiring a flow sleeve are:

- Well diameter is too large to meet Table 3 flow requirements.

- Pump is in an open body of water.
- Pump is in a rock well or below the well casing.
- The well is “top-feeding” (aka cascading).
- Pump is set in or below screens or perforations.

Water Temperature and Flow

Franklin Electric’s standard submersible motors, except Hi-Temp designs (see note below), are designed to operate up to maximum service factor horsepower in water up to (86 °F) 30 °C. A flow of 0.25 ft/s for 4" motors rated (3 hp) 2.2 KW and higher, and 0.5 ft/s for 6" and 8" motors is required for proper cooling. Table 3 shows minimum flow rates, in gpm, for various well diameters and motor sizes.

If a standard motor is operated in water over (86 °F) 30 °C, water flow past the motor must be increased to maintain safe motor operating temperatures. See HOT WATER APPLICATIONS on page 7.

NOTE: Franklin Electric offers a line of Hi-Temp motors designed to operate in water at higher temperatures or lower flow conditions. Consult factory for details.

TABLE 3 Required Cooling Flow

Minimum gpm required for motor cooling in water up to 86 °F (30 °C).			
Casing or Sleeve ID mm (inches)	4" Motor (2.2-7.5 KW) 7.62 cm/s l/m (gpm)	6" Motor 15.24 cm/s l/m (gpm)	8" Motor 15.24 cm/s l/m (gpm)
102 (4)	4.5 (1.2)	-	-
127 (5)	26.5 (7)	-	-
152 (6)	49 (13)	34 (9)	-
178 (7)	76 (20)	95 (25)	-
203 (8)	114 (30)	170 (45)	40 (10)
254 (10)	189 (50)	340 (90)	210 (55)
305 (12)	303 (80)	530 (140)	420 (110)
356 (14)	416 (110)	760 (200)	645 (170)
406 (16)	568 (150)	1060 (280)	930 (245)

7.62 cm/sec = 0.25 ft/s 15.24 cm/sec = 0.50 ft/s
2.54 cm = 1 inch

Flow Inducer Sleeve

If the flow rate is less than specified or coming from above the pump, then a flow inducer sleeve must be used. A flow sleeve is always required in an open body of water. FIG 1 shows a typical flow inducer sleeve construction.

EXAMPLE: A six-inch motor and pump that delivers 200 l/m will be installed in a 254 mm well. From Table 6, 340 l/m would be required to maintain proper cooling. In this case adding an 203 mm or smaller flow sleeve provides the required cooling.

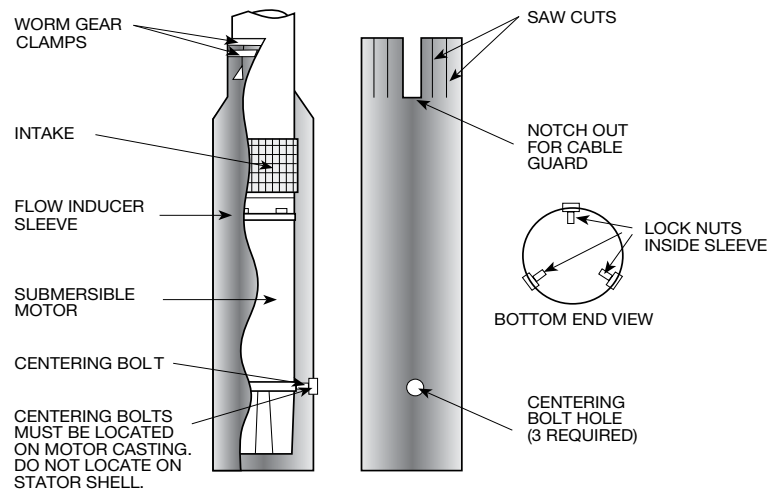

FIG. 1



Application - All Motors

Head Loss Past Motor

Table 4 lists the approximate head loss due to flow between an average length motor and smooth casing or flow inducer sleeve.

TABLE 4 Head Loss in Meters at Various Flow Rates

Motor Diameter	4"	4"	4"	6"	6"	6"	8"	8"	
Casing ID in mm	102	127	152	152	178	203	206	254	
Flow Rate in l/m	95	0.09							
	189	0.37							
	378	1.4	0.09		0.52				
	568	3.1	0.18	0.06	1.1				
	757		0.34	0.12	1.9	0.15		2.1	
	946		0.55	0.21	2.9	0.24		3.2	
	1136		0.75	0.3	4.1	0.37	0.06	4.5	
	1514				7.2	0.61	0.12	7.5	
	1893					0.94	0.21	11.4	0.2
	2271					1.3	0.3	15.9	0.3
	3028								0.5
	3785								0.7

Hot Water Applications

Franklin Electric offers a line of Hi-Temp motors which are designed to operate in water with various temperatures up to 194 °F (90 °C) without increased flow. When a standard pump-motor operates in water hotter than 86 °F (30 °C), a flow rate of at least 3 ft/s is required. When selecting the motor to drive a pump in over 86 °F (30 °C) water, the motor horsepower must be de-rated per the following procedure.

- Using Table 4A, determine pump lpm required for different well or sleeve diameters. If necessary, add a flow sleeve to obtain at least .91 m/sec flow rate.

TABLE 4A Minimum l/m Required for .91 m/sec Flow Rate

Casing or Sleeve I.D.	4" High Thrust Motor	6" Motor	8" Motor
mm	l/m	l/m	l/m
102	57		
127	303		
152	606	197	
178		568	
203		984	227
254		1970	1250
305			2460
356			3860
406			5530



Application - All Motors

- Determine pump KW (HP) required from the pump manufacturer's curve.

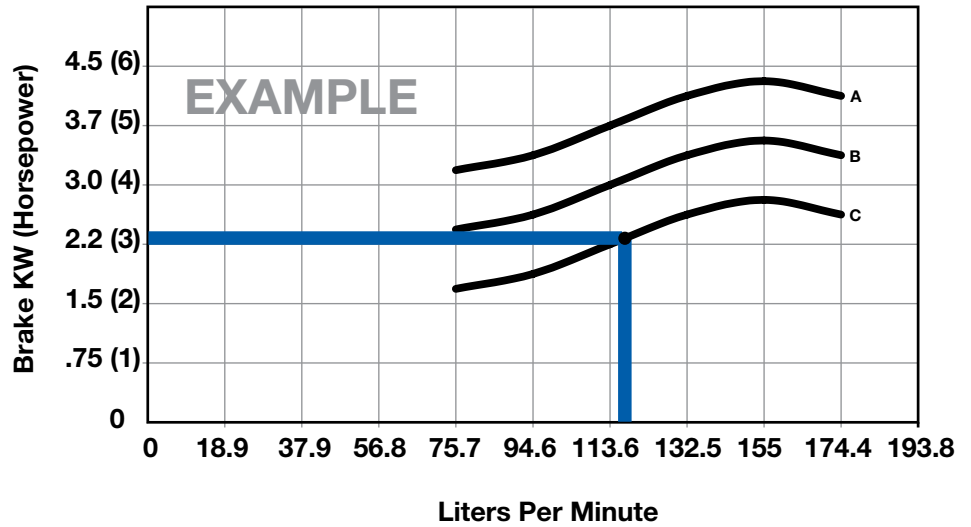

FIG. 2 MANUFACTURER'S PUMP CURVE

- Multiply the pump KW (HP) required by the heat factor multiplier from Table 5.

TABLE 5 Heat Factor Multiplier at .91 m/sec Flow Rate

Maximum Water Temperature	1/3 - 5 HP .25 - 3.7 KW	7 1/2 - 30 HP 5.5 - 22 KW	Over 30HP Over 22 KW
60°C	1.25	1.62	2.00
55°C	1.11	1.32	1.62
50°C	1.00	1.14	1.32
45°C	1.00	1.00	1.14
40°C	1.00	1.00	1.00
35°C	1.00	1.00	1.00

- Select a rated KW (HP) motor on table 5A whose Service Factor Horsepower is at least the value calculated in Item 3.

TABLE 5A Service Factor Horsepower

HP	KW	SFHP	HP	KW	SFHP	HP	KW	SFHP	HP	KW	SFHP
1/3	0.25	0.58	3	2.2	3.45	25	18.5	28.75	100	75	115.00
1/2	0.37	0.80	5	3.7	5.75	30	22.0	34.50	125	93	143.75
3/4	0.55	1.12	7.5	5.5	8.62	40	30.0	46.00	150	110	172.50
1	0.75	1.40	10	7.5	11.50	50	37.0	57.50	175	130	201.25
1.5	1.10	1.95	15	11.0	17.25	60	45.0	69.00	200	150	230.00
2	1.50	2.50	20	15.0	23.00	75	55.0	86.25			

Hot Water Applications - Example

EXAMPLE: A 6" pump end requiring 29.1 KW (39 HP) input will pump 51°C water in an 203 mm well at a delivery rate of 530 l/m. From table 4A, a 152 mm flow sleeve will be required to increase the flow rate to at least .91 m/sec.

Using table 5, the 1.62 heat factor multiplier is selected because the KW (HP) required is over 22 KW (30 HP) and

water temperature is above 50°C. Multiply 29.1 KW x 1.62 (multiplier), which equals 47.1 KW (63.2 HP). This is the minimum rated full load horsepower usable at 21.9 KW (39 HP) in 51°C. Using table 5A, select a motor with a rated service factor above 47.1 KW (63.2 HP). A 45 KW (60 HP) motor has a service factor kilowatt of 51.4 (69 HP), so a 45 kw (60 HP) motor may be used.



Application - All Motors

Drawdown Seals

Allowable motor temperature is based on atmospheric pressure or higher surrounding the motor. "Drawdown seals," which seal the well to the pump above its intake

to maximize delivery, are not recommended, since the suction created can be lower than atmospheric pressure.

Grounding Control Boxes and Panels

The United States National Electrical Code requires that the control box or panel-grounding terminal always be connected to supply ground. If the circuit has no grounding conductor and no metal conduit from the box to supply panel, use a wire at least as large as line conductors and connect as required by the National Electrical Code, from the grounding terminal to the electrical supply ground.

Connect earth grounds to control boxes and panels per local and national codes or regulations.

WARNING: Failure to ground the control frame can result in a serious or fatal electrical shock.

Grounding Surge Arrestors

An above ground surge arrestor must be grounded, metal to metal, all the way to the lowest draw down water strata for the surge arrestor to be effective. GROUNDING THE ARRESTOR TO THE SUPPLY GROUND OR TO A DRIVEN GROUND ROD PROVIDES LITTLE OR NO PROTECTION FOR THE MOTOR.

Control Box and Panel Environment

Franklin Electric control boxes, Pumptec products and three-phase panels meet UL requirements for NEMA Type 3R enclosures. They are suitable for indoor and outdoor applications within temperatures of -10 °C (+14 °F) to 50 °C (122 °F). Operating control boxes below +14 °F can cause reduced starting torque and loss of overload protection when overloads are located in control boxes.

Control boxes, Pumptec products and three-phase panels should never be mounted in direct sunlight or

high temperature locations. This will cause shortened capacitor life (where applicable) and unnecessary tripping of overload protectors. A ventilated enclosure painted white to reflect heat is recommended for an outdoor, high temperature location.

A damp well pit, or other humid location, accelerates component failure from corrosion.

Control boxes with voltage relays are designed for vertical upright mounting only. Mounting in other positions will affect the operation of the relay.

Equipment Grounding

WARNING: Serious or fatal electrical shock may result from failure to connect the motor, control enclosures, metal plumbing and all other metal near the motor or cable to the power supply ground terminal using wire no smaller than motor cable wires.

The primary purpose of grounding the metal drop pipe and/or metal well casing in an installation is safety. It is done to limit the voltage between nonelectrical (exposed metal) parts of the system and ground, thus minimizing dangerous shock hazards. Using wire at least the size of the motor cable wires provides adequate current-carrying capability for any ground fault that might occur. It also provides a low resistance path to ground, ensuring that the current to ground will be large enough to trip any overcurrent device designed to detect faults (such as a ground fault circuit interrupter, or GFCI).

Normally, the ground wire to the motor would provide the

primary path back to the power supply ground for any ground fault. There are conditions, however, where the ground wire connection could become compromised. One such example would be the case where the water in the well is abnormally corrosive or aggressive. In this example, a grounded metal drop pipe or casing would then become the primary path to ground. However, the many installations that now use plastic drop pipes and/or casings require further steps to be taken for safety purposes, so that the water column itself does not become the conductive path to ground.

When an installation has abnormally corrosive water AND the drop pipe or casing is plastic, Franklin Electric recommends the use of a GFCI with a 10 mA set-point. In this case, the motor ground wire should be routed through the current-sensing device along with the motor power leads. Wired this way, the GFCI will trip only when a ground fault has occurred AND the motor ground wire is no longer functional.



Application - Single-Phase Motors

3-Wire Control Boxes

Single-phase three-wire submersible motors require the use of control boxes. Operation of motors without control boxes or with incorrect boxes can result in motor failure and voids warranty.

Control boxes contain starting capacitors, a starting relay, overload protectors, and, in some sizes, running capacitors.

Potential (Voltage) Relays

Potential relays have normally closed contacts. When power is applied, both start and main motor windings are energized, and the motor starts. At this instant, the voltage across the start winding is relatively low and not enough to open the contacts of the relay.

As the motor accelerates, the increasing voltage across the start winding (and the relay coil) opens the relay contacts. This opens the starting circuit and the motor continues to run on the main winding alone, or the main plus run capacitor circuit. After the motor is started the relay contacts remain open.

CAUTION: The control box and motor are two pieces of one assembly. Be certain that the control box and motor hp and voltage match. Since a motor is designed to operate with a control box from the same manufacturer, we can promise warranty coverage only when a Franklin control box is used with a Franklin motor.

2-Wire Motor Solid State Controls

BIAC Switch Operation

When power is applied the bi-metal switch contacts are closed so the triac is conducting and energizes the start winding. As RPM increases, the voltage in the sensor coil generates heat in the bi-metal strip, causing the bi-metal strip to bend and open the switch circuit. This removes the starting winding and the motor continues to run on the main winding alone.

Approximately 5 seconds after power is removed from the motor, the bi-metal strip cools sufficiently to return to its closed position and the motor is ready for the next start cycle. If, during operation, the motor speed drops, the lowered voltage in the sensor coil allows the bi-metal contacts to close, and bring the motor back to operating speed.

Rapid Cycling

The BIAC starting switch will reset within approximately 5 seconds after the motor is stopped. If an attempt is made to restart the motor before the starting switch has reset, the motor may not start; however, there will be

current in the main winding until the overload protector interrupts the circuit. The time for the protector to reset is longer than the reset of the starting switch. Therefore, the start switch will have closed and the motor will operate.

A waterlogged tank will cause fast cycling. When a waterlogged condition does occur, the user will be alerted to the problem during the off time (overload reset time) since the pressure will drop drastically. When the waterlogged tank condition is detected the condition should be corrected to prevent nuisance tripping of the overload protector.

Bound Pump (Sandlocked)

When the motor is not free to turn, as with a sandlocked pump, the BIAC switch creates a “reverse impact torque” in the motor in either direction. When the sand is dislodged, the motor will start and operate in the correct direction.

CAUTION: Restarting the motor within 5 seconds after power is removed may cause the motor overload to trip.



Application - Single-Phase Motors

2- or 3-Wire Cable, 50 Hz (Service Entrance to Motor - Maximum Length In Meters & Feet)

Cable for submersible motors must be suitable for submerged operation, and adequate in size to operate within rated temperature and maintain adequate voltage at the motor. Cable may be twisted conductors with or without jacket, or flat molded type. Franklin 50HZ cable selections maintain motor voltage to at least 95% of supply voltage with maximum rated running amps, and maintain acceptable starting voltage and cable temperature.

Minimum Square Millimeter cable for each rating is based on IEC Publication 364-5-523 (1983 Edition). Jacketed cable is based on Table 52-B1, Installation Method C In Table Using Column C in Table 52-C3 (70°C). Individual conductor is based on Table 52-B2, Installation Method G using Column 6 In Table 52-C10 (70°C).

Minimum AWG Cable sizes are based on the National Electrical Code in Table 430-150 for 75°C Cable In 30°C Maximum Ambient. Use Larger Cable if Local Codes Or Higher Temperatures Require It. Lengths in Bold Meet IEC and NEC Ampacity only For Individual Conductor Cables in air or water, not in conduit.

Tables list the maximum recommended lengths in Meters for square millimeter copper cable sizes and in feet for AWG copper cable sizes. The single-phase tables apply to all three wire types, and control boxes where required, may be at any point in the cable length. The portion of cable from service entrance to a three-phase controller should not exceed 25% of table maximum length to assure reliable starter operation.

TABLE 6 Single-Phase Maximum Length of Copper Cable (meters)

Motor Rating			Metric Cable Size - 70° C Insulation - Copper Wire - Square Millimeters										
Volts	KW	HP	1.5	2.5	4	6	10	16	25	35	50	70	95
220 Volt 50Hz.	.25	1/3	190	320	510	770	1260	1970	2960	3990	5340	6970	8750
	.37	1/2	120	210	330	500	820	1290	1950	2640	3560	4680	5910
	.55	3/4	80	140	230	350	580	900	1360	1830	2450	3210	4020
	.75	1.0	60	110	180	270	440	690	1050	1430	1930	2550	3230
	1.1	1.5	40	70	120	190	310	490	750	1020	1390	1860	2380
	1.5	2.0	30	60	100	150	250	400	620	850	1180	1590	2070
	2.2	3.0	20	40	60	100	170	270	410	560	770	1030	1320
	3.7	5.0	0	0	40	60	110	170	260	370	520	710	930

1 Meter = 3.3 feet

TABLE 6A Single-Phase Motor Maximum Length of Copper Cable (feet)

Motor Rating			American Wire Gauge, 75° C Insulation - AWG Cable in Feet										
Volts	KW	HP	14	12	10	8	6	4	3	2	1	0	00
220 Volt 50 Hz.	.25	1/3	900	1450	2310	3530	5480	8460					
	.37	1/2	580	940	1500	2310	3600	5580	6830	8470			
	.55	3/4	400	660	1050	1610	2510	3890	4750	5880	7150	8670	
	.75	1.0	310	500	800	1240	1940	3010	3690	4580	5610	6840	8350
	1.1	1.5	210	350	560	870	1360	2130	2620	3270	4020	4930	6060
	1.5	2.0	170	280	450	710	1120	1770	2180	2730	3390	4180	5160
	2.2	3.0	110	190	300	470	750	1170	1440	1800	2220	2730	3360
	3.7	5.0	0	120	190	300	480	760	940	1180	1480	1830	2280



Application - Single-Phase Motors

Two different cable sizes can be used.

Depending on the installation, any number of combinations of cable may be used.

For example, in a replacement/upgrade installation, the well already has 40 meters of buried 4mm² cable between the service entrance and the wellhead. A new 2.2kW, 230-volt, single-phase motor is being installed in a bore at 50 meters to replace a small motor. The question is: Since there is already 40M of 4mm² installed, what size cable is required in the well with a 2.2kW, 230-volt, single-phase motor setting at 50 meters?

From table 11, a 2.2kW motor can use up to 60 meters of 4mm² cable. The application has 40 meters of 4mm² copper wire installed.

Using the formula below, 40M (actual) ÷ 60M (max allowable) is equal to 0.666. This means 66.6% (0.666 x 100) of the allowable voltage drop occurs in this wire. This leaves us 33.4% (1.00 - 0.666 = 0.334) of some other wire size to use in the remaining 50 meters “down hole” wire run.

FIRST EXAMPLE

The table shows 6mm² copper wire is good for 100 meters. Using the formula again, 50M (used) ÷ 100 feet (allowed) = 0.5; adding this to the 0.666 determined earlier; 0.666 + 0.5 = 1.16. This combination is greater than 1.00, so the voltage drop will not meet the ANSZ3000 recommendations.

SECOND EXAMPLE

Tables 11 show 10mm² copper wire is good for 170 meters. Using the formula, 50 ÷ 170 = 0.294, and using these numbers, 0.666 + 0.294 = 0.96, we find this is less than 1.00 and will meet the ANSZ3000 recommended voltage drop.

This works for two, three or more combinations of wire and it does not matter which size wire comes first in the installation.

Formula:
$$\frac{\text{Actual Length}}{\text{Max Allowed}} + \frac{\text{Actual Length}}{\text{Max Allowed}} = 1.00$$

EXAMPLE: 2.2kW, 230-Volt, Single-Phase Motor

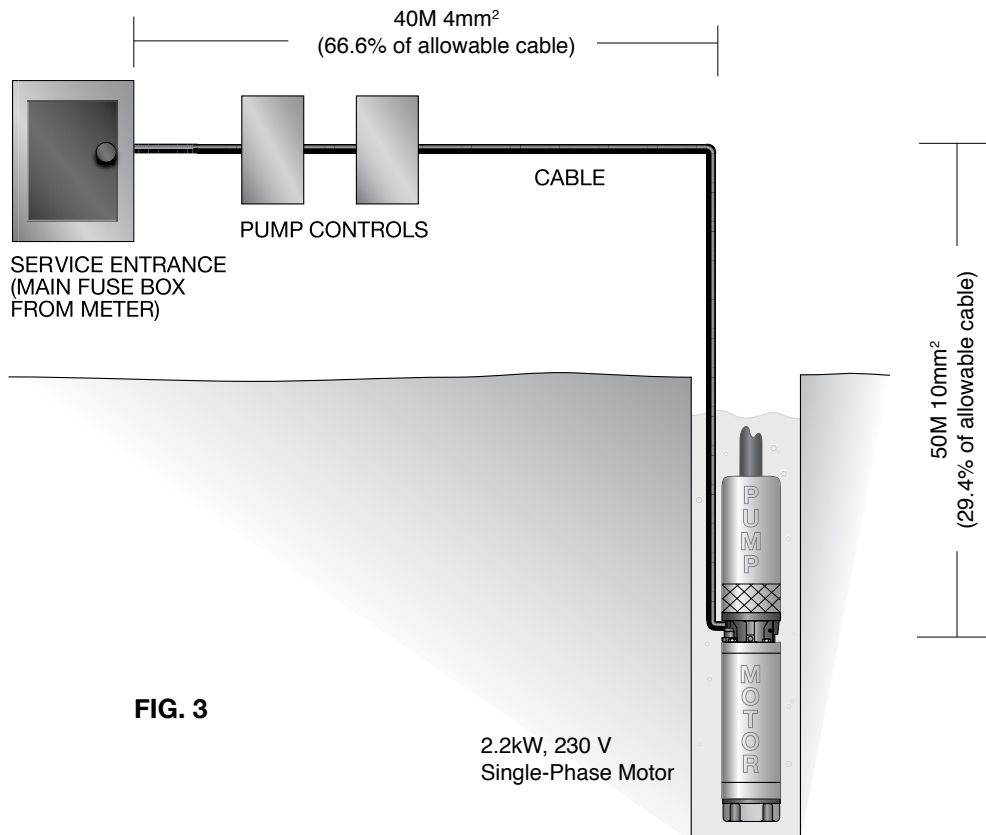

FIG. 3

2.2kW, 230 V
Single-Phase Motor



Application - Single-Phase Motors

TABLE 7 Single-Phase Motor Specifications (50 Hz), 2875 RPM, 1.0 Service Factor

Type	Motor Model Prefix	Nameplate Rating					Full Load Watts	Line to Line (1) Resistance (Ohms)		Efficiency %			Power Factor %			Locked Rotor Amps	Circuit Breakers or Fuse Amps	
		KW	HP	Volts	Line Volts	Amps		Main	Start	F.L.	3/4	1/2	F.L.	3/4	1/2		Typical Submersible	
																	Nontime Delay (Std.) Fuse or Circuit Breaker	Dual Element Time Delay Fuse
4 Inch 2-Wire	244555	.37	1/2	220	220	3.9	610	6.3 - 7.7	-	62	59	51	73	64	53	25.0	15	5
				230	230	4.1	630	6.3 - 7.7	-	59	55	47	68	60	50	26.1	15	5
	244557	.55	3/4	220	220	6.0	880	3.7 - 4.6	-	63	59	52	70	62	53	30.0	20	7
				230	230	6.5	920	3.7 - 4.6	-	61	56	48	67	59	49	36.6	20	7
	244558	.75	1	220	220	7.3	1180	3.2 - 3.9	-	65	62	55	75	66	54	42.0	20	9
				230	230	7.6	1200	3.2 - 3.9	-	63	59	52	71	63	52	43.9	20	9
244359	1.1	1 1/2	220	220	10.6	1800	2.2 - 2.7	-	64	61	56	78	70	58	50.6	30	12	
			230	230	10.8	1820	2.2 - 2.7	-	63	60	53	73	65	54	52.9	30	12	
4 Inch 3-Wire Cap. Start	214555	.37	1/2	220	220	4.2	650	6.4 - 7.8	19.4 - 23.7	57	54	46	72	64	53	15.4	15	4.5
	214557	.55	3/4	220	220	6.3	940	3.8 - 4.6	14.7 - 18.0	59	55	47	69	60	50	23.0	15	7
	214558	.75	1	220	220	7.6	1200	3.2 - 3.9	12.8 - 15.7	62	59	52	73	65	53	29.1	20	9
4 Inch 3-Wire Cap. Start-Cap. Run	224350	1.1	1 1/2	220	220	10.0	1690	2.4 - 2.9	6.4 - 7.8	67	63	55	79	63	55	40.6	20	12
	224351	1.5	2	220	220	12.1	2160	2.0 - 2.5	8.0 - 9.7	69	67	60	85	77	65	54.3	30	15
	224352	2.2	3	220	220	17.8	3270	1.1 - 1.4	3.7 - 4.5	68	66	63	85	77	65	87.5	50	25
	224353	3.7	5	220	220	26.0	5150	.79 - .97	2.4 - 2.9	73	71	64	93	89	78	118	70	30

(1) Main winding - yellow to black
Start winding - yellow to red

Performance is typical, not guaranteed, at specified voltages and specified capacitor values.

Performance at voltage ratings not shown is similar, except amps vary inversely with voltage.



Application - Three-Phase Motors

TABLE 8 Three and Six Wire Cable, 50 Hz Service Entrance to Motor - Maximum Length in Meters 70°C

Motor Rating			Metric Cable Size, Square Millimeters, Copper Wire - 70°C Rated Insulation																	
Volts	KW	HP	1.5	2.5	4	6	10	16	25	35	50	70	95	120	150	185	240	300	400	
220v 50Hz 3Ø 3 - Lead <small>(230V may use 110% of table) (240V may use 119% of table)</small>	.37	1/2	300	510	820	1230	2010	3160	4810	6540	8890									
	.55	3/4	200	350	550	830	1370	2150	3280	4460	6060	8060								
	.75	1	160	270	430	650	1070	1680	2550	3470	4710	6250	7970	9510						
	1.1	1 1/2	110	190	300	450	750	1170	1790	2430	3310	4400	5620	6700	7790	8970				
	1.5	2	80	140	230	340	570	900	1380	1880	2570	3430	4410	5290	6180	7150	8470	9670		
	2.2	3	50	90	150	230	380	600	920	1270	1740	2330	3000	3610	4230	4910	5840	6700	7790	
	3	4	40	70	110	170	280	440	670	920	1270	1700	2180	2630	3080	3570	4240	4850	5630	
	3.7	5	30	50	90	130	220	360	550	750	1030	1390	1790	2150	2520	2930	3480	4000	4640	
	4	5 1/2	30	50	80	120	200	320	490	670	920	1240	1590	1910	2240	2590	3070	3520	4070	
	5.5	7 1/2	0	30	60	90	150	240	380	520	710	960	1240	1490	1750	2040	2430	2790	3250	
	7.5	10	0	0	40	60	110	170	270	370	500	680	870	1050	1230	1420	1690	1930	2230	
	11	15	0	0	0	40	80	120	190	270	370	500	650	790	930	1080	1290	1490	1740	
	15	20	0	0	0	0	60	90	150	200	280	380	500	610	720	840	1010	1170	1370	
	18.5	25	0	0	0	0	0	70	110	160	220	300	390	480	570	660	800	920	1090	
	22	30	0	0	0	0	0	60	100	130	190	260	330	400	480	560	670	780	910	
380v 50Hz 3Ø 3 - Lead <small>(400V may use 110% of table) (415V may use 119% of table)</small>	.37	1/2	930	1550	2460	3670	6030	9460												
	.55	3/4	630	1050	1670	2500	4100	6440	9790											
	.75	1	490	820	1300	1950	3200	5020	7620											
	1.1	1 1/2	340	570	910	1360	2240	3520	5350	7280	9890									
	1.5	2	260	430	700	1040	1720	2700	4120	5630	7690									
	2.2	3	170	290	460	700	1150	1810	2770	3790	5190	6950	8950							
	3	4	120	210	340	510	840	1330	2030	2770	3790	5070	6530	7840	9190					
	3.7	5	100	170	270	410	680	1080	1650	2260	3090	4140	5340	6420	7540	8750				
	4	5 1/2	90	150	250	370	610	970	1480	2020	2770	3700	4750	5710	6680	7740	9180			
	5.5	7 1/2	70	110	190	280	470	740	1140	1560	2140	2870	3700	4460	5240	6090	7250	8330	9700	
	7.5	10	50	80	130	200	330	530	810	1110	1510	2030	2610	3130	3670	4250	5040	5770	6680	
	11	15	0	60	90	140	240	380	590	810	1120	1510	1950	2350	2770	3230	3860	4450	5200	
	15	20	0	0	70	110	180	290	450	620	860	1160	1500	1820	2150	2520	3020	3490	4110	
	18.5	25	0	0	0	80	140	230	350	490	680	910	1190	1440	1700	1990	2390	2770	3260	
	22	30	0	0	0	0	120	190	300	410	570	770	1000	1210	1440	1680	2010	2330	2740	
	30	40	0	0	0	0	140	220	310	420	570	740	900	1060	1230	1470	1700	1990		
	37	50	0	0	0	0	110	180	240	340	460	590	710	840	980	1170	1350	1580		
	45	60	0	0	0	0	0	150	200	280	380	490	600	700	820	980	1130	1330		
	55	75	0	0	0	0	0	120	170	240	330	420	510	610	710	860	990	1170		
75	100	0	0	0	0	0	0	0	180	240	320	390	460	530	640	740	880			
90	125	0	0	0	0	0	0	0	0	190	240	290	350	400	480	550	650			
110	150	0	0	0	0	0	0	0	0	0	210	250	290	340	410	470	550			
130	175	0	0	0	0	0	0	0	0	0	180	220	260	300	360	420	500			
150	200	0	0	0	0	0	0	0	0	0	0	190	230	270	320	370	440			

6 - Lead Wye - Delta

Motor Rating			Metric Cable Size, Square Millimeters, Copper Wire - 70°C Rated Insulation																
Volts	KW	HP	1.5	2.5	4	6	10	16	25	35	50	70	95	120	150	185	240	300	400
220v 50Hz 3Ø 6 - Lead <small>(230V = 110%) (240V = 119%)</small>	3.7	5	40	70	130	190	330	540	820	1120	1540	2080	2680	3220	3780	4390	5220	6000	6960
	5.5	7 1/2	30	40	90	130	220	360	570	780	1060	1440	1860	2230	2620	3060	3640	4180	4870
	7.5	10	0	30	60	90	160	250	400	550	750	1020	1300	1570	1840	2130	2530	2890	3340
	11	15	0	30	40	60	120	180	280	400	550	750	970	1180	1390	1620	1930	2230	2610
	15	20	0	0	30	40	90	130	220	300	420	570	750	910	1080	1260	1510	1750	2050
	18.5	25	0	0	0	30	60	100	160	240	330	450	580	720	850	990	1200	1380	1630
22	30	0	0	0	0	60	90	150	190	280	390	490	600	720	840	1000	1170	1360	
380v 50Hz 3Ø 6 - Lead <small>(400V may use 110% of table) (415V may use 119% of table)</small>	3.7	5	150	250	400	610	1020	1620	2470	3390	4630	6210	8010	9630					
	5.5	7 1/2	100	160	280	420	700	1110	1710	2340	3210	4300	5550	6690	7860	9130			
	7.5	10	70	120	190	300	490	790	1210	1660	2260	3040	3910	4690	5500	6370	7560	8650	
	11	15	40	90	130	210	360	570	880	1210	1680	2260	2920	3520	4150	4840	5790	6670	7800
	15	20	30	60	100	160	270	430	670	930	1290	1740	2250	2730	3220	3780	4530	5230	6160
	18.5	25	0	40	70	120	210	340	520	730	1020	1360	1780	2160	2550	2980	3580	4150	4890
	22	30	0	0	70	100	180	280	450	610	850	1150	1500	1810	2160	2520	3010	3490	4110
	30	40	0	0	0	70	130	210	330	460	630	850	1110	1350	1590	1840	2200	2550	2980
	37	50	0	0	0	0	100	160	270	360	510	690	880	1060	1260	1470	1750	2020	2370
	45	60	0	0	0	0	90	130	220	300	420	570	730	900	1050	1230	1470	1690	1990
	55	75	0	0	0	0	0	120	180	250	360	490	630	760	910	1060	1290	1480	1750
	75	100	0	0	0	0	0	90	130	190	270	360	480	580	690	790	960	1110	1320
	90	125	0	0	0	0	0	0	100	150	210	280	360	430	520	600	720	820	970
110	150	0	0	0	0	0	0	0	120	180	240	310	370	430	510	610	700	820	
130	175	0	0	0	0	0	0	0	0	150	210	270	330	390	450	540	630	750	
150	200	0	0	0	0	0	0	0	0	130	180	240	280	340	400	480	550	660	

Lengths in **BOLD** meet the IEC ampacity only for individual conductor cable in free air or water, not in conduit.

Ampacities are determined from IEC publication 364-5-523 (1983 edition).

Jacketed cable is based on Table 52-B1, Installation method C using Column C in Table 52-C3 (70°C).

Individual Conductor is based on Table 52-B2, Installation method G using Column 6 in Table 52-C10 (70°C).

1 Meter = 3.3 feet



Application - Three-Phase Motors

TABLE 9 Three and Six Wire Cable, 50Hz Service Entrance to Motor - Maximum Length in Feet

75°C

Motor Rating			AWG Wire Size, Copper Wire - 75°C Rated Insulation												MCM	MCM	MCM	MCM			
Volts	KW	HP	14	12	10	8	6	4	3	2	1	0	00	000	0000	250	300	350	400		
220v 50Hz 3Ø 3 - Lead (230V may use 110% of table) (240V may use 119% of table)	0	1/2	1420	2290	3640	5620	8800														
	.55	3/4	960	1550	2470	3820	5980	9320													
	.75	1	750	1210	1930	2980	4660	7260	8920												
	1.1	1 1/2	520	840	1340	2080	3270	5090	6260	7790	9570										
	1.5	2	390	640	1030	1600	2510	3920	4830	6020	7420	9100									
	2.2	3	260	430	680	1070	1680	2630	3240	4050	5000	6150	7570	9180							
	3	4	190	310	500	780	1230	1920	2370	2960	3650	4490	5520	6690	8090	9280					
	3.7	5	150	250	400	630	1000	1560	1930	2410	2980	3660	4510	5470	6620	7600	8710	9810			
	4	5 1/2	130	220	360	570	890	1400	1730	2160	2660	3270	4030	4880	5890	6760	7730	8700	9520		
	5.5	7 1/2	100	170	270	430	680	1080	1330	1660	2060	2530	3120	3790	4590	5270	6050	6820	7480		
	7.5	10	0	0	190	300	480	760	940	1180	1460	1790	2210	2670	3230	3710	4240	4770	5230		
	11	15	0	0	0	220	350	560	690	870	1080	1330	1640	1990	2420	2780	3200	3610	3970		
	15	20	0	0	0	170	270	430	530	660	820	1020	1260	1530	1870	2150	2480	2800	3090		
	18.5	25	0	0	0	0	210	330	410	520	650	800	990	1210	1470	1700	1960	2220	2450		
	22	30	0	0	0	0	0	280	350	440	550	680	840	1020	1250	1440	1650	1870	2060		
380v 50Hz 3Ø 3 - Lead (400V may use 110% of table) (415V may use 119% of table)	.37	1/2	4280	6880																	
	.55	3/4	2900	4670	7140																
	.75	1	2260	3640	5780	8920															
	1.1	1 1/2	1580	2550	4050	6250	9780														
	1.5	2	1210	1940	3090	4790	7510														
	2.2	3	800	1300	2060	3210	5030	7870	9690												
	3	4	580	950	1510	2350	3690	5760	7090	8850											
	3.7	5	470	770	1220	1910	3000	4690	5780	7210	8900										
	4	5 1/2	420	690	1100	1710	2690	4200	5180	6460	7970	9780									
	5.5	7 1/2	320	520	840	1310	2060	3230	3990	4980	6150	7560	9320								
	7.5	10	230	370	600	930	1470	2300	2840	3540	4370	5360	6600	7990	9650						
	11	15	160	270	430	680	1070	1690	2080	2600	3220	3970	4900	5950	7230	8310	9550				
	15	20	0	0	330	520	820	1290	1590	1990	2470	3040	3760	4590	5580	6430	7410	8380	9230		
	18.5	25	0	0	260	410	640	1010	1250	1570	1950	2400	2970	3620	4410	5080	5860	6630	7310		
	22	30	0	0	0	340	540	860	1060	1330	1650	2030	2510	3060	3730	4290	4950	5590	6160		
	30	40	0	0	0	0	400	640	790	990	1230	1510	1870	2270	2760	3170	3650	4120	4530		
	37	50	0	0	0	0	0	510	630	790	980	1200	1490	1810	2200	2530	2910	3290	3610		
	45	60	0	0	0	0	0	420	520	660	820	1010	1240	1510	1840	2120	2400	2750	3030		
55	75	0	0	0	0	0	0	450	560	700	860	1060	1300	1580	1820	2100	2380	2620			
75	100	0	0	0	0	0	0	0	0	520	640	800	980	1190	1370	1580	1790	1970			
90	125	0	0	0	0	0	0	0	0	0	0	620	750	920	1050	1210	1360	1500			
110	150	0	0	0	0	0	0	0	0	0	0	0	0	640	770	890	1020	1160	1270		
130	175	0	0	0	0	0	0	0	0	0	0	0	0	0	670	780	900	1020	1120		
150	200	0	0	0	0	0	0	0	0	0	0	0	0	0	600	690	790	900	990		

6 - Lead Wye - Delta

Motor Rating			AWG Wire Size, Copper Wire - 75°C Rated Insulation												MCM	MCM	MCM	MCM		
Volts	KW	HP	14	12	10	8	6	4	3	2	1	0	00	000	0000	250	300	350	400	
220v 50Hz 3Ø 6 - Lead (230V = 110%) (240V = 119%)	3.7	5	220	370	600	940	1500	2340	2890	3610	4470	5490	6760	8200	9930					
	5.5	7 1/2	150	250	400	640	1020	1620	1990	2490	3090	3790	4680	5680	6880	7900	9070			
	7.5	10	100	180	280	450	720	1140	1410	1770	2190	2680	3310	4000	4840	5560	6360	7150	7840	
	11	15	70	120	210	330	520	840	1030	1300	1620	1990	2460	2980	3630	4170	4800	5410	5950	
	15	20	0	0	150	250	400	640	790	990	1230	1530	1890	2290	2800	3220	3720	4200	4630	
	18.5	25	0	0	120	190	310	490	610	780	970	1200	1480	1810	2200	2550	2940	3330	3670	
22	30	0	0	0	160	270	420	520	660	820	1020	1260	1530	1870	2160	2470	2800	3090		
380v 50Hz 3Ø 6 - Lead (400V may use 110% of table) (415V may use 119% of table)	3.7	5	700	1150	1830	2860	4500	7030	8670											
	5.5	7 1/2	480	780	1260	1960	3090	4840	5980	7470	9220									
	7.5	10	340	550	900	1390	2200	3450	4260	5310	6550	8040	9900							
	11	15	240	400	640	1020	1600	2530	3120	3900	4830	5950	7350	8920						
	15	20	180	300	490	780	1230	1930	2380	2980	3700	4560	5640	6880	8370	9640				
	18.5	25	150	240	390	610	960	1510	1870	2350	2920	3600	4450	5430	6610	7620	8790	9940		
	22	30	0	190	330	510	810	1290	1590	1990	2470	3040	3760	4590	5590	6430	7420	8380	9240	
	30	40	0	0	240	370	600	960	1180	1480	1840	2260	2800	3400	4140	4750	5470	6180	6790	
	37	50	0	0	0	300	480	760	940	1180	1470	1800	2230	2710	3300	3790	4360	4930	5410	
	45	60	0	0	0	250	400	630	780	990	1230	1510	1860	2260	2760	3180	3660	4120	4540	
	55	75	0	0	0	0	340	540	670	840	1050	1290	1590	1950	2370	2730	3150	3570	3930	
	75	100	0	0	0	0	0	400	490	630	780	960	1200	1470	1780	2050	2370	2680	2950	
90	125	0	0	0	0	0	0	390	490	610	750	930	1120	1380	1570	1810	2040	2250		
110	150	0	0	0	0	0	0	0	400	510	630	780	960	1150	1330	1530	1740	1900		
130	175	0	0	0	0	0	0	0	0	430	540	670	820	1000	1170	1350	1530	1680		
150	200	0	0	0	0	0	0	0	0	0	480	600	730	900	1030	1180	1350	1480		

1 Meter = 3.3 feet

Lengths in **BOLD** meet the IEC ampacity only for individual conductor cable in free air or water, not in conduit. Ampacities are determined from motor full load current Table 430-150 in the National Electrical Code.



Application - Three-Phase Motors

TABLE 10 Three-Phase Motor Specifications (50 Hz), 2875 RPM, 1.0 Service Factor

Type	Motor Model Prefix	Nameplate Rating				Full Load Watts	Line to Line (1) Resistance (Ohms)	Efficiency %	Power Factor %	Locked Rotor Amps	Circuit Breakers or Fuse Amps		
		KW	HP	Volts	Amps						Typical Submersible		
								Nontime Delay (Std.) Fuse or Circuit Breaker	Dual Element Time Delay Fuse				
F.L.	F.L.												
4 Inch	234551	.37	1/2	220	1.8	560	18.3 - 22.4	66	82	7.3	15	2.5	
	234561			380	1.1	560	56.8 - 69.4	66	82	4.3	15	1.2	
	234552	.55	3/4	220	2.6	810	12.3 - 15.0	69	83	10	15	3	
	234562			380	1.6	810	38.6 - 47.2	69	86	5.9	15	1.8	
	234553	0.75	1	220	3.5	1055	8.4 - 10.3	71	83	15	15	4	
	234563			380	2.1	1055	26.1 - 31.9	71	83	9.0	15	2.5	
	234554	1.1	1 1/2	220	5.2	1465	4.3 - 5.2	76	83	24	15	6	
	234524			380	3.0	1465	13.2 - 16.2	76	83	14	15	3	
	234355	1.5	2	220	6.9	1970	3.0 - 3.7	76	84	35	15	8	
	234325			380	4.0	1970	9.4 - 11.5	76	84	20	15	4.5	
	234356	2.2	3	220	10.4	2930	2.1 - 2.7	76	86	46	25	12	
	234326			380	6.0	2930		76	86	26			
				400	6.0	2920	6.7 - 8.2	77	82	27	15	7	
	234394	3	4	220	12.6	3940	1.5 - 1.8	76	87	64	35	15	
				234395	380	7.3	3940		76	87	36		
					400	7.3	3910	4.9 - 6.0	76	84	38	20	9
	234357	3.7	5	220	15.5	4860	1.1 - 1.4	77	84	80	40	20	
				234327	380	9.0	4860		77	84	46		
					400	9.1	4875	3.6 - 4.4	77	79	48	25	10
	234396	4	5 1/2	220	18.0	5275	1.0 - 1.3	78	86	89	45	20	
234397				380	10.1	5275		78	86	51			
				400	10.4	5210	3.2 - 3.9	79	82	53	25	12	
234358	5.5	7 1/2	220	22.8	7175	.75 - .92	78	85	120	60	30		
			234328	380	13.0	7175		78	85	69			
				400	13.1	7155	2.3 - 2.8	78	80	73	35	15	
234595	7.5	10	380	18.7	9580		78	86	99				
			400	18.8	9550	1.7 - 2.1	78	81	102	50	25		

Performance is typical, not guaranteed, at specified voltages.
Performance of 1984 and older models, not listed is similar, but not identical.



Application - Three-Phase Motors

TABLE 11 Three-Phase Motor Specifications (50 Hz), 2875 RPM, 1.0 Service Factor

Type	Motor Model Prefix	Nameplate Rating					Full Load Watts	Line to Line (1) Resistance (Ohms)	Efficiency %			Power Factor %			Locked Rotor Amps	Circuit Breakers or Fuse Amps	
		KW	HP	Volts	Line Volts	Amps			F.L.	3/4	1/2	F.L.	3/4	1/2		Typical Submersible	
																Nontime Delay (Std.) Fuse or Circuit Breaker	Dual Element Time Delay Fuse
6 Inch	236680	3.7	5	220	220	15.4	4850	1.3 - 1.6	77	76	73	84	78	66	68	40	20
	236610			380	400	8.8	4900	3.9 - 4.8	77	71	59	79	71	59	42	25	10
	236681			415	9.3	4950	75	73	67	74	64	52	43	25	10		
	236681	5.5	7 1/2	220	220	21.9	7175	.79 - .97	78	79	77	85	80	70	105	60	25
	236611			380	400	12.5	7100	2.4 - 2.9	79	78	74	82	75	63	64	35	15
	236682			415	12.8	7175	78	77	74	78	70	57	66	35	15		
	236682	7.5	10	220	220	28.5	9450	.63 - .77	79	80	77	87	83	74	143	75	35
	236612			380	400	16.0	9450	1.9 - 2.4	79	79	75	86	80	70	83	45	20
	236613			415	16.2	9450	79	78	75	81	74	62	91	45	20		
	236683	11	15	220	220	41.8	13750	.38 - .47	81	82	80	87	82	62	218	110	50
	236613			380	400	23.0	13750	1.1 - 1.4	81	80	78	84	80	64	125	60	30
	236684			415	24.1	13750	81	80	77	82	75	63	133	60	30		
	236614	15	20	220	220	55.3	18200	.26 - .33	82	83	81	87	84	75	283	150	60
	236614			380	400	31.3	18500	.83 - 1.0	81	81	79	85	80	69	170	80	35
	236685			415	31.0	18500	81	81	77	83	77	65	174	80	35		
	236615	18.5	25	220	220	69.1	23000	.20 - .25	81	83	82	89	85	76	340	175	80
	236615			380	400	40.0	23000	.62 - .77	81	83	82	89	85	76	197	100	45
	236686			415	38.5	22700	82	82	80	82	75	62	215	100	45		
	236616	22	30	220	220	82.9	27250	.16 - .21	82	83	82	88	86	78	440	225	90
	236616			380	400	45.3	27000	.52 - .64	82	83	82	88	86	78	255	125	55
236617	415			45.5	27000	83	83	81	86	81	71	268	125	55			
236617	30	40	220	220	64.1	36000	.34 - .42	83	84	83	87	82	72	362	175	75	
236618			380	400	63.5	36000	.25 - .32	83	84	82	85	79	69	417	200	90	
236618			415	64.6	36000	83	82	80	79	71	58	397	175	75			
236618	37	50	220	220	80.1	45000	.25 - .32	83	84	83	87	84	76	395	200	90	
236618			380	400	77.9	45000	.25 - .32	83	84	82	85	79	69	417	200	90	
236618			415	77.9	45000	83	83	81	82	76	64	434	200	90			
276618	37	50	220	220	95.5	45000	.25 - .32	83	84	83	87	84	76	395	200	90	
236619			380	400	93.9	45000	.22 - .27	83	84	82	85	79	69	417	200	90	
236619			415	93.2	45000	83	83	81	82	76	64	434	200	90			
236619	45	50/60	220	220	95.5	54000	.22 - .27	83	84	84	87	84	75	478	250	110	
236619			380	400	93.9	54000	.22 - .27	83	84	83	84	79	69	506	250	110	
276619			415	93.2	54000	83	84	81	82	75	64	526	250	110			
236619	45	50/60	220	220	96.8	54000	.22 - .27	83	84	84	87	84	75	478	250	110	
236619			380	400	95.2	54000	.22 - .27	83	84	83	84	79	69	506	250	110	
236619			415	94.5	54000	83	84	81	82	75	64	526	250	110			
8 Inch	239600	30	40	380	380	61.0	34700	.247 - .303	86	86	85	88	84	75	397	175	70
	239600			400	61.0	34700	.185 - .226	87	87	85	89	85	78	507	200	90	
	239600			415	62.0	34700	86	85	82	80	73	62	433	175	70		
	239601	37	50	380	380	75.0	43000	.185 - .226	87	87	85	89	85	78	507	200	90
	239601			400	74.0	43000	.142 - .174	87	87	85	85	81	71	534	200	90	
	239601			415	74.0	43000	87	86	83	83	76	66	654	200	90		
	239602	51	60	380	380	89.0	51500	.142 - .174	87	87	86	89	85	77	612	250	100
	239602			400	89.0	51500	.106 - .130	87	87	85	85	81	71	645	250	100	
	239602			415	89.0	51500	87	86	84	82	76	65	669	250	100		
	239603	55	75	380	380	111.0	64000	.106 - .130	88	88	86	89	86	79	819	300	125
	239603			400	108.0	64000	.073 - .089	88	87	84	84	78	66	895	300	125	
	239603			415	108.0	64000	88	87	84	84	78	66	895	300	125		
	239604	75	100	380	380	148.0	85000	.073 - .089	88	88	86	89	86	79	1099	400	175
	239604			400	145.0	86000	.055 - .067	87	87	85	87	82	72	1157	400	175	
	239604			415	145.0	86000	87	87	84	84	78	67	1200	400	175		
	239105	90	125	380	380	194.0	107000	.055 - .067	87	87	85	86	83	75	1265	500	225
	239105			400	190.0	107000	.042 - .051	87	86	84	83	78	68	1332	500	225	
	239105			415	191.0	107000	87	86	83	80	74	63	1382	500	225		
	239106	110	150	380	380	226.0	127000	.042 - .051	88	88	86	87	84	77	1517	600	300
	239106			400	222.0	127000	.042 - .052	88	87	85	84	80	70	1597	600	300	
239106	415			223.0	127000	88	87	84	81	75	64	1657	600	300			
239107	130	175	380	380	260.0	150000	.042 - .052	87	87	86	89	87	83	1651	700	300	
239107			400	252.0	148000	.036 - .044	88	87	86	87	84	79	1733	700	300		
239107			415	247.0	148000	88	87	85	86	81	74	1803	700	300			
239108	150	200	380	380	294.0	170000	.036 - .044	88	88	86	90	88	83	1765	800	350	
239108			400	284.0	170000	.036 - .044	88	88	86	88	86	79	1858	800	350		
239108			415	277.0	170000	88	88	86	87	83	75	1928	800	350			

Performance is typical, not guaranteed, at specified voltages.
 Locked rotor amps for Wye start 6 lead motors is 33% of value shown.
 Performance also applies to 6 lead model numbers where not listed.
 Six lead individual phase resistance = table X 1.5.



TABLE 12 Hi Temp 90°C Three-Phase Motor Specifications (50Hz), 2875 RPM, 1.0 Service Factor

Type	Motor Model Prefix	Nameplate Rating					Full Load Watts	Line to Line (1) Resistance (Ohms)	Efficiency %			Power Factor %			Locked Rotor Amps
		KW	HP	Volts	Line Volts	Amps			F.L.	3/4	1/2	F.L.	3/4	1/2	
6 INCH HI-Temp 90C	276 610	3.7	5	380-415	380	8.8	5000	2.79 - 3.41	74	72	66	88	85	78	49.9
					400	8.5	5000		75	72	66	86	82	74	52.5
					415	8.4	5000		75	72	65	84	79	70	54.5
	276 611	5.5	7.5	380-415	380	12.7	7300	1.66 - 2.03	77	75	70	88	85	77	78.6
					400	12.3	7200		77	75	70	86	81	72	83.0
					415	12.3	7200		77	75	69	84	77	67	86.0
	276 612	7.5	10	380-415	380	24.4	9400	1.18 - 1.44	80	78	74	88	84	76	105
					400	24.2	9300		81	79	74	85	79	69	110
					415	24.4	9400		80	77	71	83	76	65	114
	276 613	11	15	380-415	380	33.3	13900	.78 - .96	80	79	75	85	83	74	152
					400	33.0	13800		80	79	74	82	77	67	160
					415	33.3	14000		79	78	73	79	73	61	166
	276 614	15	20	380-415	380	40.7	18700	.58 - .72	80	79	76	87	82	73	195
					400	40.5	18700		80	79	75	83	77	65	205
					415	41.4	18700		80	78	74	80	72	60	213
	276 615	18.5	25	380-415	380	49.2	22600	.41 - .51	82	82	79	86	80	70	253
					400	48.0	22500		83	82	78	82	74	62	266
					415	47.9	22700		82	80	76	78	69	57	276
276 616	22	30	380-415	380	65.0	27800	.34 - .42	80	79	76	88	83	76	289	
				400	64.5	27700		81	79	75	85	80	70	304	
				415	65.6	27800		80	79	74	82	76	65	316	
276 617	30	40	380-415	380	65.5	35900	.23 - .29	83	82	80	86	80	70	419	
				400	64.5	35800		83	82	79	82	75	63	441	
				415	65.6	36000		83	81	77	78	70	58	458	
8 INCH HI-Temp 75C	279 100	30	40	380-415	380	66.8	37000	.16 - .19	80	78	72	0.86	0.82	0.76	474
					400	65.5	37000		80	78	72	0.83	0.78	0.7	499
					415	65.8	37000		80	77	71	0.8	0.74	0.65	518
	279 101	37	50	380-415	380	80.7	45000	.11 - .14	83	80	75	0.87	0.83	0.76	654
					400	79.6	45000		82	80	74	0.84	0.79	0.7	692
					415	80.1	46000		82	79	73	0.81	0.75	0.65	720
	279 102	45	60	380-415	380	94.3	53000	.09 - .11	85	83	78	0.87	0.82	0.75	835
					400	93.1	53000		84	82	77	0.84	1.78	0.69	884
					415	93	53000		84	82	76	0.81	0.74	0.64	920
	279 103	55	75	380-415	380	118	67000	.07 - .09	84	82	78	0.87	0.84	0.77	876
					400	115	66000		84	82	78	0.85	0.81	0.72	927
					415	113	66000		84	82	77	0.83	0.78	0.69	965
	279 104	75	100	380-415	380	155	87000	.05 - .07	85	84	81	0.87	0.83	0.76	1185
					400	151	87000		86	84	80	0.85	0.8	0.71	1254
					415	150	87000		85	84	80	0.82	0.78	0.66	1306
	279 105	93	125	380-415	380	191	109000	.04 - .06	86	85	81	0.88	0.85	0.78	1404
					400	186	109000		86	84	81	0.86	0.8	0.73	1482
					415	184	109000		86	84	80	0.84	0.76	0.69	1544
279 106	110	150	380-415	380	231	131000	.03 - .05	85	84	81	0.88	0.84	0.77	1596	
				400	224	130000		86	84	81	0.85	0.81	0.72	1690	
				415	222	130000		86	84	80	0.83	0.77	0.68	1760	

Performance is typical, not guaranteed, at specific voltages.
 Locked rotor amps for Wye start 6 lead motors is 33% of value shown.
 Performance also applies to 6 lead model numbers where not listed.
 Six lead individual phase resistance = table X 1.5.

Refer to Table 17 for fuse sizing recommendations at equal KW values.



Application - Three-Phase Motors

Overload Protection of Three-Phase Submersible Motors

Motor Protection, Selection of Thermal Overload Relays

Characteristics of submersible motors differ from standard motors and special overload protection is required. In order to provide sufficient protection against overload and locked rotor, the relay has to be of the following characteristic:

- Conform to European standards e.g. VDE providing trip time < 10 sec. at 500% I_N (name plate current) based on cold bimetal
- Protection against single phasing
- Must trip at 120% I_N (name plate current)
- Temperature compensated to avoid nuisance tripping

The specific information can be obtained directly from the manufacturer's catalog. They are available from a Current/Time curve as shown on the right.

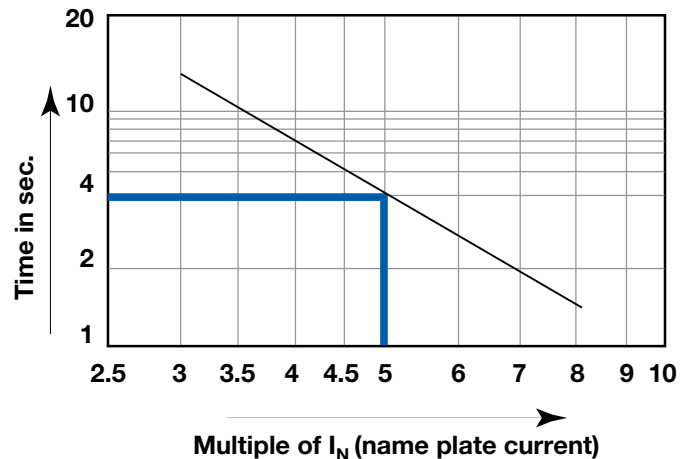

FIG. 4

For optimal protection a FE Subtrol, Submonitor or adjustable overload recommended

Overload setting, DOL and $Y\Delta$ start

For DOL, max. at full current I_N shown on nameplate.

For $Y\Delta$, relay must be incorporated in the delta circuit for adequate protection on Y start and set at $I_N \times 0.58$.

Recommended setting for all applications is the measured current value at duty point.

Setting $> I_N$ is not allowed.



Application - Three-Phase Motors

SubMonitor Three- Phase Protection

Applications

SubMonitor is designed to protect 3-phase pumps/ motors with service factor amp ratings (SFA) from 5 to 350 A (approx. 2.2 to 150 kW). Current, voltage, and motor temperature are monitored using all three legs and allows the user to set up the SubMonitor quickly and easily.

Protects Against

- Under/Overload
- Under/Overtoltage
- Current Unbalance
- Overheated Motor
(if equipped with Subtrol Heat Sensor)
- False Start (Chattering)
- Phase Reversal



Power Factor Correction

In some installations, power supply limitations make it necessary or desirable to increase the power factor of a submersible motor. The table lists the capacitive KVAR required to increase the power factor of large Franklin three-phase submersible motors to the approximate values shown at maximum input loading.

Capacitors must be connected on the line side of the overload relay, or overload protection will be lost.

TABLE 13 KVAR Required 50 Hz

Motor		KVAR Required for P.F. of:		
KW	HP	0.90	0.95	1.00
3.7	5	.8	1.5	3.1
5.5	7 1/2	1.0	2.1	4.5
7.5	10	.8	2.2	5.3
11	15	1.1	3.3	7.8
15	20	1.8	4.3	9.6
18.5	25	3	6.5	14
22	30	3	7.5	17
30	40	5	10	22
37	50	5	12	27
45	60	5	13	30
55	75	5	15	37
75	100	4	18	46
90	125	18	35	72
110	150	18	38	82
130	175	13	37	88
150	200	10	37	95

Values listed are total required (not per phase).



Application - Three-Phase Motors

Three-Phase Starter Diagrams

Three-phase combination magnetic starters have two distinct circuits: a power circuit and a control circuit.

The power circuit consists of a circuit breaker or fused line switch, contacts, and overload heaters connecting incoming power lines L1, L2, L3 and the three-phase motor.

The control circuit consists of the magnetic coil, overload

contacts and a control device such as a pressure switch. When the control device contacts are closed, current flows through the magnetic contactor coil, the contacts close, and power is applied to the motor. Hands-Off-Auto switches, start timers, level controls and other control devices may also be in series in the control circuit.

Line Voltage Control

This is the most common type of control encountered. Since the coil is connected directly across the power lines, L1 and L2, the coil must match the line voltage.

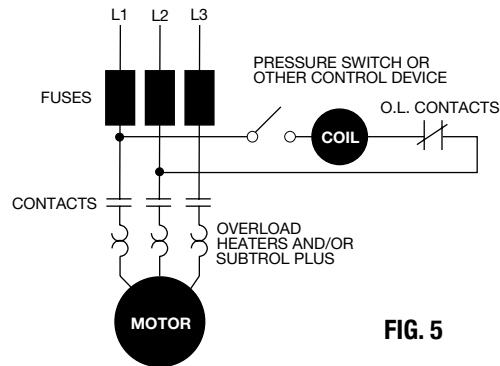

FIG. 5

Low Voltage Transformer Control

This control is used when it is desirable to operate push buttons or other control devices at some voltage lower than the motor voltage. The transformer primary must match the line voltage and the coil voltage must match the secondary voltage of the transformer.

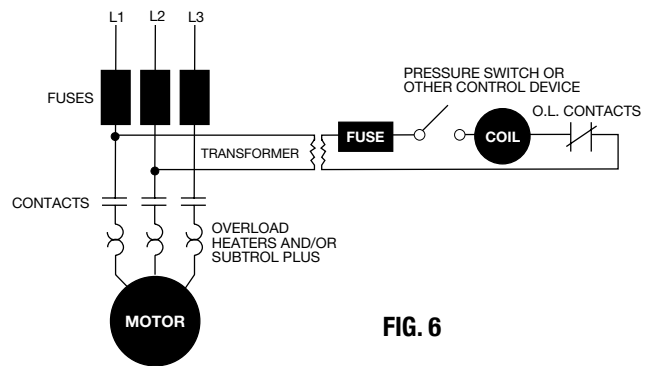

FIG. 6

External Voltage Controls

Control of a power circuit by a lower circuit voltage can also be obtained by connecting to a separate control voltage source. The coil rating must match the control voltage source, such as 115 or 24 volts.

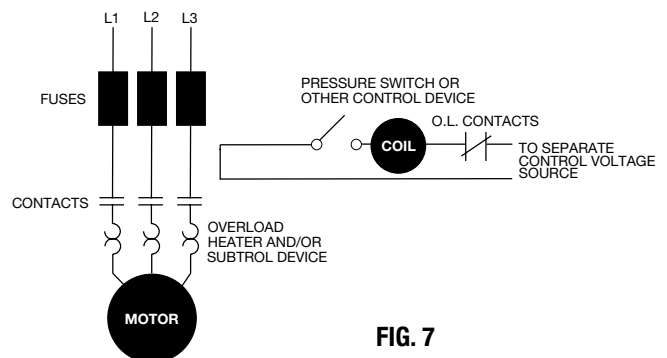

FIG. 7



Application - Three-Phase Motors

Three-Phase Power Unbalance

A full three-phase supply is recommended for all three-phase motors, consisting of three individual transformers or one three-phase transformer. So-called “open” delta or wye connections using only two transformers can be used, but are more likely to cause problems, such

as poor performance, overload tripping or early motor failure due to current unbalance.

Transformer rating should be no smaller than listed in Table 2 for supply power to the motor alone

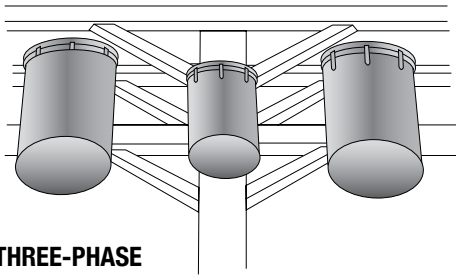

FIG. 8 FULL THREE-PHASE

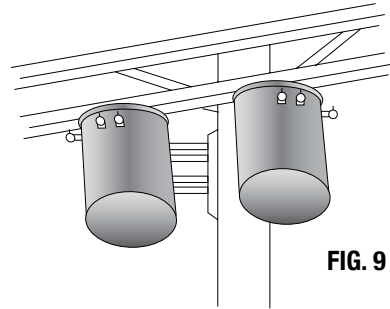

FIG. 9 OPEN DELTA

Checking and Correcting Rotation and Current Unbalance

- Established correct motor rotation by running in both directions. Change rotation by exchanging any two of the three motor leads. The rotation that gives the most water flow is always the correct rotation.
- After correct rotation has been established, check the current in each of the three motor leads and calculate the current unbalance as explained in 3 below.
If the current unbalance is 2% or less, leave the leads as connected.

If the current unbalance is more than 2%, current readings should be checked on each leg using each of three possible hook-ups. Roll the motor leads across the starter in the same direction to prevent motor reversal.

- To calculate percent of current unbalance:
 - Add the three line amps values together.
 - Divide the sum by three, yielding average current.
 - Pick the amp value which is furthest from the average current (either high or low).
 - Determine the difference between this amp value (furthest from average) and the average.
 - Divide the difference by the average. Multiply the result by 100 to determine percent of unbalance.
- Current unbalance should not exceed 5% at full load. If the unbalance cannot be corrected by rolling leads, the source of the unbalance must be located and corrected. If, on the three possible hookups, the leg farthest from the average stays on the same power lead, most of the unbalance is coming from the power source. However, if the reading farthest from average moves with the same motor lead, the primary source of unbalance is on the “motor side” of the starter. In this instance, consider a damaged cable, leaking splice, poor connection, or faulty motor winding.

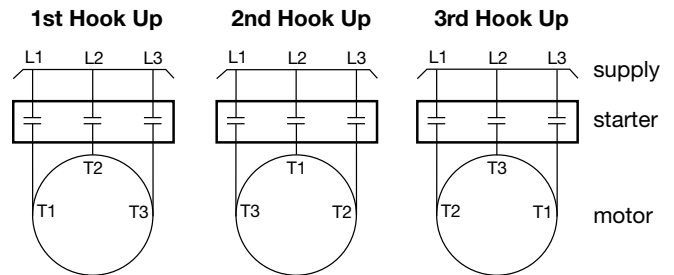

EXAMPLE:

T1 = 51 amps	T3 = 50 amps	T2 = 50 amps
T2 = 46 amps	T1 = 49 amps	T3 = 48 amps
+ T3 = 53 amps	+ T2 = 51 amps	+ T1 = 52 amps
<u>Total = 150 amps</u>	<u>Total = 150 amps</u>	<u>Total = 150 amps</u>

$\frac{150}{3} = 50$ amps	$\frac{150}{3} = 50$ amps	$\frac{150}{3} = 50$ amps
---------------------------	---------------------------	---------------------------

50 - 46 = 4 amps	50 - 49 = 1 amp	50 - 48 = 2 amps
------------------	-----------------	------------------

$\frac{4}{50} = .08$ or 8%	$\frac{1}{50} = .02$ or 2%	$\frac{2}{50} = .04$ or 4%
----------------------------	----------------------------	----------------------------

Phase designation of leads for CCW rotation viewing shaft end.

To reverse rotation, interchange any two leads.

- Phase 1 or “A”- Black, T1, or U1
- Phase 2 or “B”- Yellow, T2, or V1
- Phase 3 or “C”- Red, T3, or W1

NOTICE: Phase 1, 2 and 3 may not be L1, L2 and L3.



Submersible Pump Installation Check List

1. Motor Inspection

- A. Verify that the model, hp or kW, voltage, phase and hertz on the motor nameplate match the installation requirements.
- B. Check that the motor lead assembly is not damaged.
- C. Measure insulation resistance using a 500 or 1000 volt DC megohmmeter from each lead wire to the motor frame. Resistance should be at least 200 megohms without drop cable.
- D. Keep a record of motor model number, hp or kW, voltage, and serial number (S/N). (S/N is stamped in shell above the nameplate. A typical example, S/N 07A18 01-0123)

2. Pump Inspection

- A. Check that the pump rating matches the motor.
- B. Check for pump damage and verify that the pump shaft turns freely.

3. Pump/Motor Assembly

- A. If not yet assembled, check that pump and motor mounting faces are free from dirt, debris and uneven paint thickness.
- B. Pumps and motors over 5 hp should be assembled in the vertical position to prevent stress on pump brackets and shafts. Assemble the pump and motor together so their mounting faces are in contact and then tighten assembly bolts or nuts evenly to manufacturer specifications.
- C. If accessible, check that the pump shaft turns freely.
- D. Assemble the pump lead guard over the motor leads. Do not cut or pinch lead wires during assembly or installation.

4. Power Supply and Controls

- A. Verify that the power supply voltage, Hertz, and kVA capacity match motor requirements.
- B. Verify control box hp and voltage matches motor (3-wire only).
- C. Check that the electrical installation and controls meet all safety regulations and match the motor requirements, including fuse or circuit breaker size and motor overload protection. Connect all metal plumbing and electrical enclosures to the power supply ground to prevent shock hazard. Comply with national and local codes.

5. Lightning and Surge Protection

- A. Use properly rated surge (lightning) arrestors on all submersible pump installations. Motors 5 hp and smaller, which are marked "Equipped with Lightning Arrestors", contain internal arrestors.
- B. Ground all above ground arrestors with copper wire directly to the motor frame, or to metal drop pipe or casing which reaches below the well pumping level. Connecting to a ground rod does not provide good surge protection.

6. Electrical Drop Cable

- A. Use submersible cable sized in accordance with local regulations and the cable charts. See pages 11 and 16-21. Ground motor per national and local codes.
- B. Include a ground wire to the motor and surge protection, connected to the power supply ground if required by codes. Always ground any pump operated outside a drilled well.

7. Motor Cooling

- A. Ensure at all times that the installation provides adequate motor cooling; see page 6 for details.



Submersible Pump Installation Check List

8. Pump/Motor Installation

- A. Splice motor leads to supply cable using electrical grade solder or compression connectors, and carefully insulate each splice with watertight tape or adhesive-lined shrink tubing, as shown in motor or pump installation data.
- B. Support the cable to the delivery pipe every 10 feet (3 meters) with straps or tape strong enough to prevent sagging. Use padding between cable and any metal straps.
- C. A check valve in the delivery pipe is recommended. More than one check valve may be required, depending on valve rating and pump setting; see page 5 for details.
- D. Assemble all pipe joints as tightly as practical, to prevent unscrewing from motor torque. Torque should be at least 10 pound feet per hp (2 meter-KG per kW).
- E. Set the pump far enough below the lowest pumping level to assure the pump inlet will always have at least the Net Positive Suction Head (NPSH) specified by the pump manufacturer. Pump should be at least 10 feet (3 meters) from the bottom of the well to allow for sediment build up.
- F. Check insulation resistance as pump/motor assembly is lowered into the well. Resistance may drop gradually as more cable enters the water, but any sudden drop indicates possible cable, splice or motor lead damage; see page 45.

9. After Installation

- A. Check all electrical and water line connections and parts before starting the pump.
- B. Start the pump and check motor amps and pump delivery. If normal, continue to run the pump until delivery is clear. If three-phase pump delivery is low, it may be running backward. Rotation may be reversed (with power off) by interchanging any two motor lead connections to the power supply.
- C. Check three-phase motors for current balance within 5% of average, using motor manufacturer instructions. Imbalance over 5% will cause higher motor temperatures and may cause overload trip, vibration, and reduced life.
- D. Verify that starting, running and stopping cause no significant vibration or hydraulic shocks.
- E. After at least 15 minutes running time, verify that pump output, electrical input, pumping level, and other characteristics are stable and as specified.

Date _____ Filled In By _____

Notes _____



Submersible Motor Installation Record

RMA No. _____

INSTALLER'S NAME _____ OWNER'S NAME _____

ADDRESS _____ ADDRESS _____

CITY _____ STATE _____ ZIP _____ CITY _____ STATE _____ ZIP _____

PHONE (____) _____ FAX (____) _____ PHONE (____) _____ FAX (____) _____

CONTACT NAME _____ CONTACT NAME _____

WELL NAME/ID _____ DATE INSTALLED _____ DATE FAILED _____

WATER TEMPERATURE _____ °C

Motor:

Motor No. _____ Date Code _____ KW _____ Voltage _____ Phase _____

Pump:

Manufacturer _____ Model No. _____ Curve No. _____ Rating: _____ l/m@ _____ m TDH

NPSH Required _____ m NPSH Available _____ m Actual Pump Delivery _____ l/m@ _____ PSI

Operating Cycle _____ ON (Min./Hr.) _____ OFF (Min./Hr.) (Circle Min. or Hr. as appropriate)

YOUR NAME _____ DATE ____/____/____

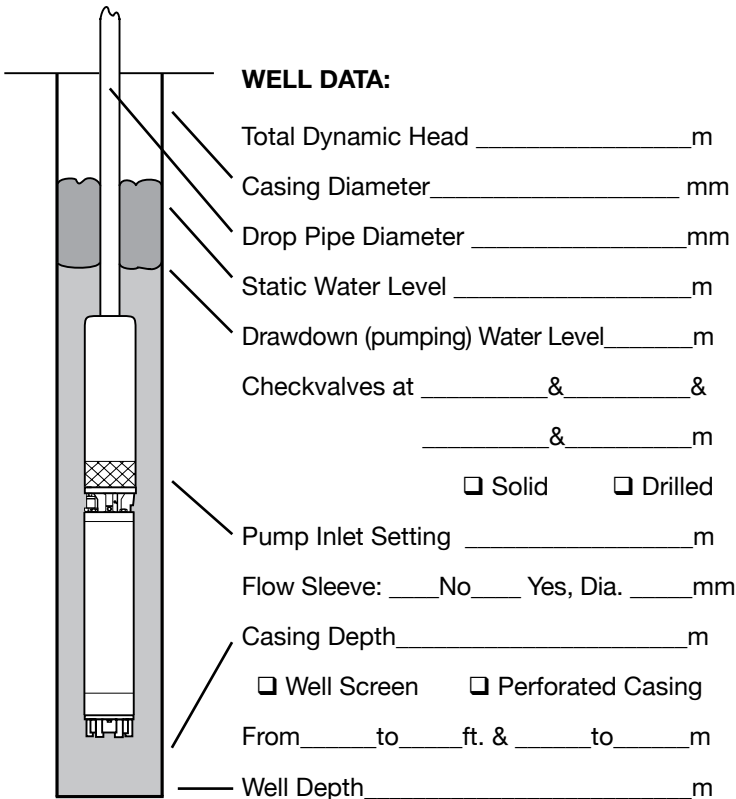

TOP PLUMBING:
Please sketch the plumbing after the well head (check valves, throttling valves, pressure tank, etc.) and indicate the setting of each device.



Submersible Motor Installation Record

Power Supply:

Cable: Service Entrance to Control _____ m _____ mm²/MCM Copper Aluminum
 Jacketed Individual Conductors

Cable: Control to Motor _____ m _____ mm²/MCM Copper Aluminum
 Jacketed Individual Conductors

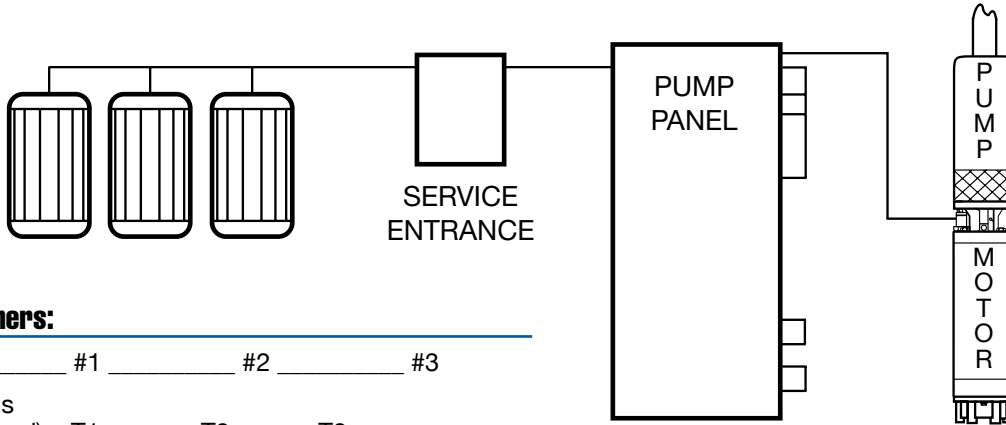

Transformers:

KVA #1 _____ #2 _____ #3 _____

Initial Megs (motor & lead) T1 _____ T2 _____ T3 _____

Final Megs (motor, lead & cable) T1 _____ T2 _____ T3 _____

Incoming Voltage:

No Load L1-L2 _____ L2-L3 _____ L1-L3 _____
Full Load L1-L2 _____ L2-L3 _____ L1-L3 _____

Running Amps:

HOOKUP 1:
Full Load L1 _____ L2 _____ L3 _____
%Unbalance _____

HOOKUP 2:
Full Load L1 _____ L2 _____ L3 _____
%Unbalance _____

HOOKUP 3:
Full Load L1 _____ L2 _____ L3 _____
%Unbalance _____

Ground Wire Size _____ mm²/MCM
Motor Surge Protection Yes No

CONTROL PANEL:

Panel Manufacturer _____

Short Circuit Device
 Circuit Breaker Rating _____ Setting _____
 Fuses Rating _____ Type _____
 Standard Delay

Starter Manufacturer _____
Starter Size _____
Type of Starter Full Voltage Autotransformer
 Other: _____ Full Voltage in _____ sec.

Heater Manufacturer _____
Number _____ Adjustable Set at _____ amps.

Subtrol-Plus No Yes Registration No. _____
If yes, Overload Set? No Yes Set at _____ amps.
Underload Set? No Yes Set at _____ amps.

Controls are Grounded to:
 Well Head Motor Rod Power Supply

Variable Frequency Drives:

Manufacturer _____ Model _____ Output Frequency: _____ Hz Min _____ Hz Max

Cooling Flow at Min. Freq. _____ Cooling Flow at Max. Freq. _____

Approved Overload: Built-in _____ External Model: (per above) Cables: (per above) Set Amps _____

Start Time _____ sec. Stop Mode Coast _____ sec. Ramp _____ sec.

Output filter _____ Reactor _____ % Make _____ Model _____ None

Maximum Load Amps:

Drive Meter Input Amps Line 1 _____ Line 2 _____ Line 3 _____

Drive Meter Output Amps Line 1 _____ Line 2 _____ Line 3 _____

Test Ammeter Output Amps Line 1 _____ Line 2 _____ Line 3 _____

Test Ammeter Make _____ Model _____



Submersible Motor Booster Installation Record

Submersible Motor Booster Installation Record

Date ____ / ____ / ____ Filled In By _____ RMA No. _____

Installation

Owner/User _____ Telephone (____) _____

Address _____ City _____

State _____ Postal Code/Zip _____ Country _____

Installation Site, If Different _____

Contact _____ Telephone (____) _____

System Application _____

System Manufactured By _____ Model _____ Serial No. _____

System Supplied By _____ City _____

State _____ Postal Code/Zip _____ Country _____

Motor

Model No. _____ Serial No. _____ Date Code _____

Horsepower/kW _____ Voltage _____ Single-Phase Three-Phase

Motor Diaphragm Height _____ in mm Motor Shaft Height _____ in mm

Slinger Removed? Yes No Check Valve Plug Removed? Yes No Motor Dia. _____ in

Does Motor Have a Deionized Fill Solution: Yes No

Pump

Manufacturer _____ Model _____ Serial No. _____

Stages _____ Diameter _____ Flow Rate Of _____ GPM At _____ TDH

Booster Case Internal Diameter _____ Material Construction _____

Controls and Protective Devices

Subtrol? Yes No If Yes, Warranty Registration No. _____

If Yes, Overload Set? Yes No Set At _____

Underload Sets? Yes No Set At _____

Reduced Voltage Starter? Yes No If Yes, Type _____

Mfr. _____ Starting _____ %Full Voltage Ramp up to Full Voltage In _____ Sec.

Variable Frequency Drive? Yes No If Yes, Mfr. _____ Model _____

Accel. Time 0 to 30Hz: _____ Sec. Max Freq. _____ Volt/Hz

Decel. Time 30 to 0Hz: _____ Sec. Min Freq. _____ Volt/Hz

Volt/Hz Profile: _____

Magnetic Starter/Contactor Mfr. _____ Model _____ Size _____

Overload Mfr. _____ Ambient Compensated Yes No

Overload Class 10 Rated Yes No Htr No. _____ If Adjustable Overload Set At _____

Circuit Protection Fuse Breaker Mfr. _____ Size _____ Type _____

Lightning/Surge Arrestor Mfr. _____ Model _____

Controls Are Grounded to _____ with No. _____ Wire



Submersible Motor Booster Installation Record

Inlet Feed Water Temp Control Required Mfr. _____ Model _____
Set At _____ °F °C Delay _____ Sec.

Inlet Pressure Control Required Ea. Mtr. Mfr. _____ Model _____ Set _____ PSI Delay _____ Sec.

Outlet Flow Control Required Ea. Mtr. Mfr. _____ Model _____ Set _____ GPM Delay _____ Sec.

Outlet Pressure Control Required Ea. Mtr. Mfr. _____ Model _____ Set _____ PSI Delay _____ Sec.

Inlet Flow Control (Optional) If Yes, Mfr. _____ Model _____ Set _____ GPM Delay _____ Sec.

Flushing

Is there a flushing cycle? Yes No

If Yes, Flushing Occurs:

Pre-Operation Yes No If Yes, _____ Duration in Min. _____ GPM or _____ PSI

Post-Operation Yes No If Yes, _____ Duration in Min. _____ GPM or _____ PSI

Chemicals Yes No If Yes, list _____

Motor Duty Cycle: Starts Per 24hrs _____ Time Between Shutdown & Start-up _____

Insulation Check

Initial Megs: Motor & Motor Lead Only T1 _____ T2 _____ T3 _____

Installed Megs: Motor, Motor Lead, & Cable T1 _____ T2 _____ T3 _____

Motor Phase to Phase Resistance T1-T2 _____ T1-T3 _____ T2-T3 _____

Voltage To Motor

Non-Operating: T1-T2 _____ T1-T2 _____ T2-T3 _____

Operating At Rated Flow _____ GPM T1-T2 _____ T1-T2 _____ T2-T3 _____

Operating At Open Flow _____ GPM T1-T2 _____ T1-T2 _____ T2-T3 _____

Amps To Motor

Operating At Rated Flow _____ GPM T1 _____ T2 _____ T3 _____

Operating At Open Flow _____ GPM T1 _____ T2 _____ T3 _____

Current System Reading

Inlet Pressure _____ PSI Outlet Pressure _____ PSI Water Temperature _____ °F °C

Warranty on three-phase motors is void unless Subtrol or proper quick trip ambient compensated protection is used on all three (3) motor lines.

If you have any questions or problems, call the Franklin Electric Toll-Free Hot Line: 1-800-348-2420

Comments: _____

Please attach a sketch of the system



Application - Three-Phase Motors

Three-Phase Motor Lead Identification

90° Lead Spacing

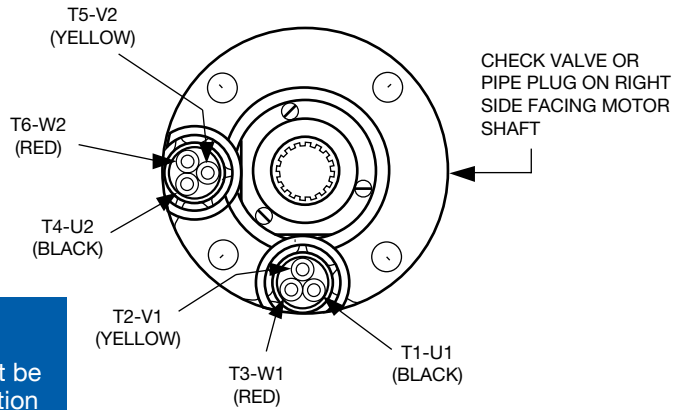

LEADS LOCATED HERE ONLY FOR 3 LEAD (DOL) MOTORS

FIG. 10

WARNING: When installing 6-lead motors extra care must be used to ensure lead identification at the surface. Leads must be marked and connected per diagram. Motor leads are not connected red to red, yellow to yellow, etc.

Line Connections — Six Lead Motors

Connections for across-the-line starting, running, and any reduced voltage starting except WYE-DELTA type starters.

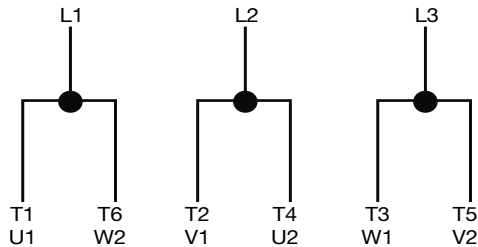

WYE-DELTA starters connect the motor as shown below during starting, then change to the running connection shown at the left.

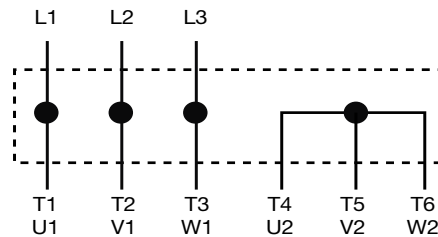

Each motor lead is numbered with two markers, one near each end. To reverse rotation; interchange any two line connections.



Application - Three-Phase Motors

Reduced Voltage Starters

All Franklin three-phase submersible motors are suitable for full-voltage starting. Under this condition the motor speed goes from zero to full speed within a half second or less. The motor current goes from zero to locked rotor amps, then drops to running amps at full speed. This may dim lights, cause momentary voltage dips to other electrical equipment, and shock power distribution transformers.

In some cases the power companies may require reduced-voltage starters to limit this voltage dip. There are also times when reduced-voltage starters may be desirable to reduce motor starting torque thus reducing the stress on shafts, couplings, and discharge piping. Reduced-voltage starters also slow the rapid acceleration of the water on start-up to help control upthrust and water hammer.

Reduced-voltage starters may not be required if the maximum recommended cable length is used. With maximum recommended cable length there is a 5% voltage drop in the cable at running amps, resulting in about 20% reduction in starting current and about 36% reduction in starting torque compared to having rated voltage at the motor. This may be enough reduction in starting current so that reduced-voltage starters are not required.

Three-Lead Motors: Autotransformer or solid-state reduced-voltage starters may be used for soft-starting standard three-phase motors.

When autotransformer starters are used, the motor should be supplied with at least 55% of rated voltage to ensure adequate starting torque. Most autotransformer starters have 65% and 80% taps. Setting the taps on these starters depends on the percentage of the maximum allowable cable length used in the system.

Inline Booster Pump Systems

Franklin Electric offers three different types of motors for non-vertical applications.

1. The **booster** motors are specifically designed for booster applications. They are the **“Best Choice” for sealed reverse osmosis applications**. These motors are the result of two years of focused development and bring additional value and durability to booster module systems. These motors are only available to OEMs or distributors who have demonstrated capability in booster module systems design and operation and adhere to Franklin’s Application Manual requirements.
2. The **Hi-Temp** motors have many of the internal design features of the booster motor. It’s additional length allows for higher temperature handling and the Sand Fighter sealing system provides greater abrasion resistance. One or both of these conditions

If the cable length is less than 50% of the maximum allowable, either the 65% or the 80% taps may be used. When the cable length is more than 50% of allowable, the 80% tap should be used.

Six-Lead Motors: Wye-Delta starters are used with six-lead Wye-Delta motors. All Franklin 6" and 8" three-phase motors are available in six-lead Wye-Delta construction. Consult the factory for details and availability. Part winding starters are not compatible with Franklin Electric submersible motors and should not be used.

Wye-Delta starters of the open-transition type, which momentarily interrupt power during the starting cycle, are not recommended. Closed-transition starters have no interruption of power during the start cycle and can be used with satisfactory results.

Reduced-voltage starters have adjustable settings for acceleration ramp time, typically preset at 30 seconds. They must be adjusted so the motor is at full voltage within THREE SECONDS MAXIMUM to prevent excessive radial and thrust bearing wear.

If Subtrol-Plus or SubMonitor is used the acceleration time must be set to TWO SECONDS MAXIMUM due to the 3 second reaction time of the Subtrol-Plus or SubMonitor.

Solid-state starters AKA soft starts may not be compatible with Subtrol-Plus/SubMonitor. However, in some cases a bypass contactor has been used. Consult the factory for details.

During shutdown, Franklin Electric’s recommendation is for the power to be removed, allowing the pump/motor to coast down. Stopping the motor by ramping down the voltage is possible, but should be limited to three (3) seconds maximum.

are often experienced in open atmosphere applications such as lakes, ponds, etc.

3. The **Standard Vertical Water Well** (30-93 kW) motors can be adapted to non-vertical applications when applied per the below guidelines. However, they will be more sensitive to application variances than the other two designs.

All of the above motors must be applied per the guidelines listed below. In addition, for all applications where the motor is applied in a sealed system, a Submersible Motor Booster Installation Record (Form 3655) or its equivalent must be completed at startup and received by Franklin Electric within 60 days. A sealed system is one where the motor and pump intake are mounted in a sleeve and the water feeding the pump intake is not open to the atmosphere.



Application - Three-Phase Motors

Inline Booster Pump Systems (continued)

Design And Operational Requirements

- 1. Non-Vertical Operation:** Vertical Shaft-up (0°) to Horizontal (90°) operation is acceptable as long as the pump transmits “down-thrust” to the motor within 3 seconds after start-up and continuously during operation. However, it is best practice to provide a positive slope whenever it is possible, even if it is only a few degrees.
- 2. Motor, Sleeve, and Pump Support System:** The booster sleeve ID must be sized according to the motor cooling and pump NPSHR requirements. The support system must support the motor’s weight, prevent motor rotation and keep the motor and pump aligned. The support system must also allow for thermal axial expansion of the motor without creating binding forces.
- 3. Motor Support Points:** A minimum of two support points are required on the motor. One in the motor/pump flange connection area and one in the bottom end of the motor area. The motor castings, not the shell area, are recommended as support points. If the support is a full length support and/or has bands in the shell area, they must not restrict heat transfer or deform the shell.
- 4. Motor Support Material and Design:** The support system shall not create any areas of cavitation or other areas of reduced flow less than the minimum rate required by this manual. They should also be designed to minimize turbulence and vibration and provide stable alignment. The support materials and locations must not inhibit the heat transfer away from the motor.
- 5. Motor and Pump Alignment:** The maximum allowable misalignment between the motor, pump, and pump discharge is 2 mm per 1000 mm of length (0.025 inch per 12 inches). This must be measured in both directions along the assembly using the motor/pump flange connection as the starting point. The booster sleeve and support system must be rigid enough to maintain this alignment during assembly, shipping, operation and maintenance.
- 6.** The best motor lubrication and heat resistance is obtained with the factory based propylene glycol fill solution. Only when an application MUST HAVE deionized (DI) water should the factory fill solution be replaced. When a deionized water fill is required, the motor must be derated as indicated on the below chart. The exchange of the motor fill solution to DI water must be done by an approved Franklin service shop or representative using a vacuum fill system per Franklin’s Motor Service Manual instruction. The

motor shell then must be permanently stamped with a D closely behind the serial number.

The maximum pressure that can be applied to the motor internal components during the removal of the factory fill solution is 7 psi (0.5 bar.)

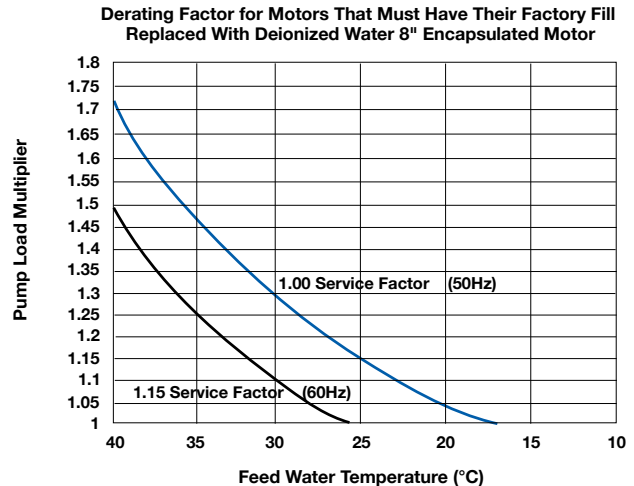

FIG. 11

- First:** Determine maximum feed water temperature that will be experienced in this application. If the feed water exceeds the maximum ambient of the motor, both the DI water derating and a hot water application derating must be applied.
 - Second:** Determine the pump load multiplier from the appropriate Service Factor curve. (Typical 1.15 Service Factor is for 60 Hz ratings & 1.00 Service Factor for 50 Hz ratings).
 - Third:** Multiply the pump load requirement times the pump load multiplier number indicated on the vertical axis to determine the minimum motor nameplate rating.
 - Fourth:** Select a motor with a nameplate equal or higher than the above calculated value.
- 7. Motor Alterations - Sand Slinger & Check Valve Plug:** On 6” and 8” motors, the rubber sand slinger located on the shaft must be removed. If a pipe plug is covering the check valve, it must be removed. The special booster motor already has these modifications.
 - 8. Frequency of Starts:** Fewer than 10 starts per 24-hour period are recommended. Allow at least 20 minutes between shutdown and start-up of the motor.



Application - Three-Phase Motors

Inline Booster Pump Systems (continued)

9. **Controls-Soft Starters and VFDs:** Reduced voltage starters and variable speed drives (inverter drives) may be used with Franklin three-phase submersible motors to reduce starting current, upthrust, and mechanical stress during start-up. The guidelines for their use with submersible motors are different than with normal air cooled motor applications. Refer to the Franklin Electric Application, Installation and Maintenance (AIM) Manual, Reduced Voltage Starters section or Variable Speed Submersible Pump Operation, Inverter Drives sections for specific details including required filtering.
10. **Motor Overload Protection:** Submersible motors require properly sized ambient compensated Class 10 quick-trip overloads per Franklin's AIM Manual guidelines to protect the motor. Class 20 or higher overloads are NOT acceptable. Franklin's SubMonitor is strongly recommended for all large submersibles since it is capable of sensing motor heat without any additional wiring to the motor. Applications using soft starters with a SubMonitor require a start-up bypass - consult the factory for details. SubMonitor can not be used in applications using a VFD control.
11. **Motor Surge Protection:** Properly sized, grounded and dedicated motor surge arrestors must be installed in the supply line of the booster module as close to the motor as possible. This is required on all systems including those using soft-starters and variable speed drives (inverter drives).
12. **Wiring:** Franklin's lead assemblies are only sized for submerged operation in water to the motor nameplate maximum ambient temperature and may overheat and cause failure or serious injury if operated in air. Any wiring not submerged must meet applicable national and local wiring codes and Franklin cable chart tables 8-9. (Notice: wire size, wire rating and insulation temperature rating must be known when determining its suitability to operate in air or conduit. Typically, for a given size and rating, as the insulation temperature rating increases its ability to operate in air or conduit also increases.)
13. **Check Valves:** Spring-loaded check valves must be used on start-up to minimize motor upthrusting, water hammer, or in multiple booster (parallel) applications to prevent reverse flow.
14. **Pressure Relief Valves:** A pressure relief valve is required and must be selected to ensure that, as the pump approaches shut-off, it never reaches the point that the motor will not have adequate cooling flow past it.
15. **System Purge (Can Flooding):** An air bleeder valve must be installed on the booster sleeve so that flooding may be accomplished prior to booster start-up. Once flooding is complete, the booster should be started and brought up to operating pressure as quickly as possible to minimize the duration of an upthrust condition. At no time should air be allowed to gather in the booster sleeve because this will prevent proper cooling of the motor and permanently damage it.
16. **System Flush – Must Not Spin Pump:** Applications may utilize a low flow flushing operation. Flow through the booster sleeve must not spin the pump impellers and the motor shaft. If spinning takes place, the bearing system will be permanently damaged and the motor life shortened. Consult the booster pump manufacturer for maximum flow rate through the pump when the motor is not energized.

Table 14 Franklin Cable chart (See 12. Wiring)

Cable Temp. Rating (°C)	Motor Nameplate Rated Amps Full Load	6mm ²		10mm ²		16mm ²		25mm ²		35mm ²	
		#10 AWG		#8 AWG		#6 AWG		#4 AWG		#2 AWG	
		In Air	In Conduit	In Air	In Conduit	In Air	In Conduit	In Air	In Conduit	In Air	In Conduit
75	3-LEAD (DOL)	40A	28A	56A	40A	76A	52A	100A	68A	136A	92A
	6-LEAD (Y-Δ)	69A	48A	97A	69A	132A	90A	173A	118A	236A	159A
90	3-LEAD (DOL)	44A	32A	64A	44A	84A	60A	112A	76A	152A	104A
	6-LEAD (Y-Δ)	76A	55A	111A	76A	145A	104A	194A	132A	263A	180A
125	3-LEAD (DOL)	66A	46A	77A	53A	109A	75A	153A	105A	195A	134A
	6-LEAD (Y-Δ)	114A	80A	133A	91A	188A	130A	265A	181A	337A	232A

Based on 30 °C maximum ambient with cable length of 100 feet or less.

Continued on next page



Application - Three-Phase Motors

Inline Booster Pump Systems (continued)

17. **Open Atmosphere Booster Pump Systems:** When an open booster is placed in a lake, tank, etc. that is open to atmospheric pressure, the water level must provide sufficient head pressure to allow the pump to operate above its NPSHR requirement at all times and all seasons. Adequate inlet pressure must be provided prior to booster start-up.

Four Continuous Monitoring System Requirements for Sealed Booster Systems.

1. **Water Temperature:** Feed water on each booster must be continuously monitored and not allowed to exceed the motor nameplate maximum ambient temperature at any time. IF THE INLET TEMPERATURE EXCEEDS THE MOTOR NAMEPLATE MAXIMUM AMBIENT TEMPERATURE, THE SYSTEM MUST SHUTDOWN IMMEDIATELY TO PREVENT PERMANENT MOTOR DAMAGE. If feed water temperatures are expected to be above the allowable temperature, the motor must be derated. See Franklin's AIM Manual, Hot Water Applications section for derating guidelines. (The high temperature feed water derating is in addition to the exchange to DI water derating if the motor factory fill solution was exchanged to DI water.)
2. **Inlet Pressure:** The inlet pressure on each booster module must be continuously monitored. It must always be positive and higher than the NPSHR (Net Positive Suction Head Requirement) of the pump. A minimum of 20 PSIG (1.38 Bar) is required at all times, except for 10 seconds or less when the motor is starting and the system is coming up to pressure. Even during these 10 seconds the pressure must remain positive and be higher than the NPSHR (Net Positive Suction Head Requirement) of the pump.

PSIG is the actual value displayed on a pressure gauge in the system piping. PSIG is the pressure above the atmospheric conditions. If at any time these pressure requirements are not being met, the motor must be de-energized immediately to prevent permanent damage to the motor. Once the motor is damaged, it is usually not immediately noticeable, but progresses and results in a premature motor failure weeks or months after the damage occurred.

Motors that will be exposed to pressure in excess of 500 psi (34.47 Bar) must undergo special high pressure testing. Consult factory for details and availability.

3. **Discharge Flow:** The flow rate for each pump must not be allowed to drop below the motor minimum cooling flow requirement. IF THE MOTOR MINIMUM COOLING FLOW REQUIREMENT IS NOT BEING MET FOR MORE THAN 10 SECONDS, THE SYSTEM MUST BE SHUT DOWN IMMEDIATELY TO PREVENT PERMANENT MOTOR DAMAGE.
4. **Discharge Pressure:** The discharge pressure must be monitored to ensure that a downthrust load toward the motor is present within 3 seconds after start-up and continuously during operation. IF THE MOTOR DISCHARGE PRESSURE IS NOT ADEQUATE TO MEET THIS REQUIREMENT, THE SYSTEM MUST BE SHUT DOWN IMMEDIATELY TO PREVENT PERMANENT MOTOR DAMAGE.



Application - Three-Phase Motors

Variable Speed Submersible Pump Operation, Inverter Drives

Franklin three-phase submersible motors are operable from variable frequency inverter drives when applied within guidelines shown below. These guidelines are based on present Franklin information for inverter drives, lab tests and actual installations, and must be followed for warranty to apply to inverter drive installations. Franklin two-wire and three-wire single-phase submersible motors are not recommended for variable speed operation.

WARNING: There is a potential shock hazard from contact with insulated cables from a PWM drive to the motor. This hazard is due to high frequency voltage content of a PWM drive output.

Load Capability: Pump load should not exceed motor nameplate service factor amps at rated voltage and frequency.

Frequency Range: Continuous between 30 Hz and rated frequency (50 or 60 Hz). Operations above rated frequency require special considerations, consult factory for details.

Volts/Hz: Use motor nameplate volts and frequency for the drive base settings. Many drives have means to increase efficiency at reduced pump speeds by lowering motor voltage. This is the preferred operating mode.

Voltage Rise-time or dV/dt : Limit the peak voltage to the motor to 1000V and keep the rise-time greater than 2 μ sec. Alternately stated: keep $dV/dt < 500V/\mu$ sec. See Filters or Reactors.

Motor Current Limits: Load no higher than motor nameplate service factor amps. For 50 Hz ratings, nameplate maximum amps are rated amps. See Overload Protection below.

Motor Overload Protection: Protection in the drive (or separately furnished) must be set to trip within 10 seconds at 5 times motor maximum nameplate amps in any line, and ultimately trip within 115% of nameplate maximum amps in any line.

Subtrol-Plus: Franklin's Subtrol-Plus protection systems ARE NOT USABLE on VFD installations.

Start and Stop: One second maximum ramp-up and ramp-down times between stopped and 30 Hz. Stopping by coast-down is preferable.

Successive Starts: Allow 60 seconds before restarting.

Filters or Reactors: Required if all three of the following conditions are met: (1) Voltage is 380 or greater and (2) Drive uses IGBT or BJT switches (rise-times $< 2 \mu$ sec) and (3) Cable from drive to motor is more than 15.2 m. A low-pass filter is preferable. Filters or reactors should be selected in conjunction with the drive manufacturer and must be specifically designed for VFD operation.

Cable Lengths: Per Franklin's cable tables unless a reactor is used. If a long cable is used with a reactor, additional voltage drop will occur between the VFD and the motor. To compensate, set the VFD output voltage higher than the motor rating in proportion to the reactor impedance (102% voltage for 2% impedance, etc.).

Motor Cooling Flow: For installations that are variable-flow, variable-pressure, minimum flow rates must be maintained at nameplate frequency. In variable-flow, constant pressure installations, minimum flow rates must be maintained at the lowest flow condition. Franklin's minimum flow requirements for 4" motors : 7.26 cm/sec. and for 6" and 8" motors: 15.24 cm/sec.

Carrier Frequency: Applicable to PWM drives only. These drives often allow selection of the carrier frequency. Use a carrier frequency at the low end of the available range.

Miscellaneous: Franklin three-phase motors are not declared "Inverter Duty" motors per NEMA MG1, Part 31 standards. However, Franklin's submersible motors can be used with VFDs without problems and/or warranty concerns provided these guidelines are followed.



Installation - All Motors

4" Super Stainless - Dimensions (Standard Water Well)

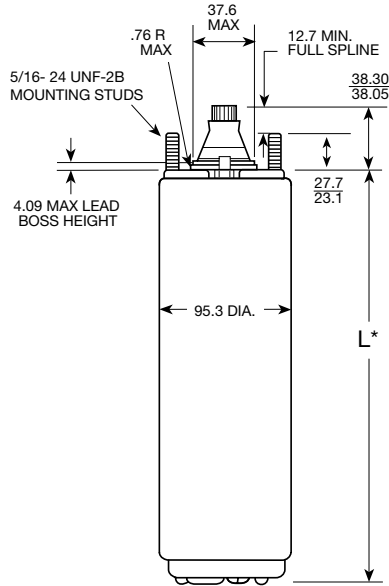

4" High Thrust - Dimensions (Standard Water Well)

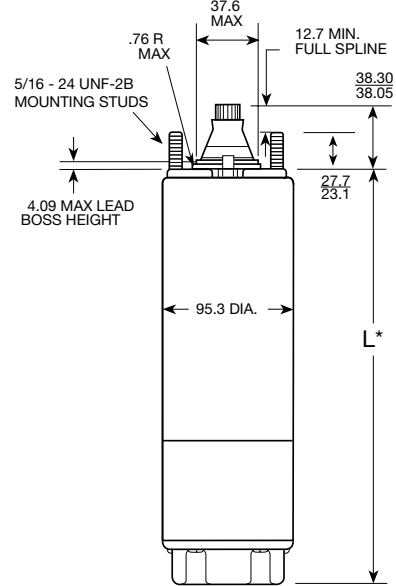

6" - Dimensions (Standard Water Well)

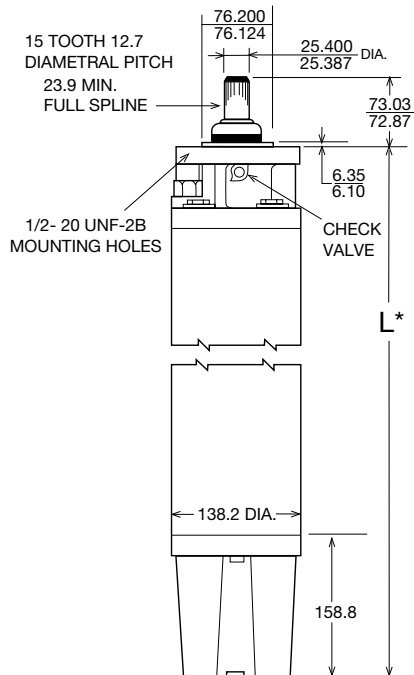

8" - Dimensions (Standard Water Well)

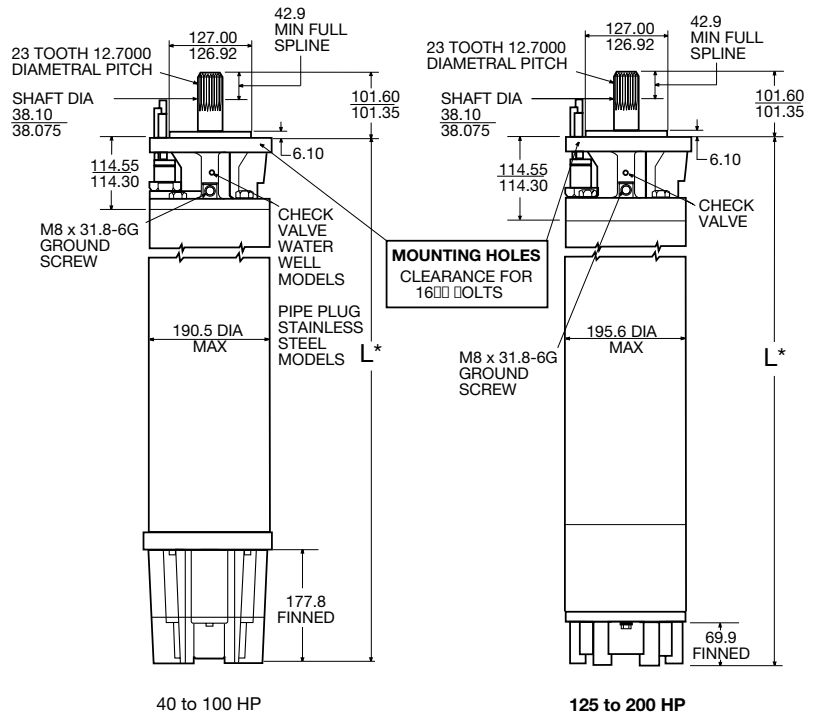

Dimensions in mm unless otherwise noted

* Motor lengths and shipping weights are available on Franklin Electric's web page (www.franklin-electric.com) or by calling Franklin's submersible hotline (800-348-2420)



Installation - All Motors

Tightening Motor Lead Connector Jam Nut

- 4" Motors with Jam Nut:**
20 to 27 Nm (15 to 20 ft-lb)
- 4" Motors with 2 Screw Clamp Plate:**
4.0 to 5.1 Nm (35 to 45 in-lb)
- 6" Motors:**
54 to 68 Nm (40 to 50 ft-lb)
- 8" Motors with 1-3/16" to 1-5/8" Jam Nut:**
68 to 81 Nm (50 to 60 ft-lb)
- 8" Motors with 4 Screw Clamp Plate:**
Apply increasing torque to the screws equally in a criss-cross pattern until 9.0 to 10.2 Nm (80 to 90 in-lb) is reached.

Jam nut tightening torques recommended for field assembly are shown. Rubber compression set within the first few hours after assembly may reduce the jam nut torque. This is a normal condition which does not indicate reduced seal effectiveness. Retightening is not required, but is permissible and recommended if original torque was questionable.

A motor lead assembly should not be reused. A new lead assembly should be used whenever one is removed from the motor, because rubber set and possible damage from removal may prevent proper resealing of the old lead.

All motors returned for warranty consideration must have the lead returned with the motor.

Pump to Motor Coupling

Assemble coupling with non-toxic FDA approved waterproof grease such as Mobile FM102, Texaco CYGNUS2661, or approved equivalent. This prevents abrasives from entering the spline area and prolongs spline life.

Pump to Motor Assembly

After assembling the motor to the pump, torque mounting fasteners to the following:

- 4" Pump and Motor:** 14 Nm (10 lb-ft)
- 6" Pump and Motor:** 68 Nm (50 lb-ft)
- 8" Pump and Motor:** 163 Nm (120 lb-ft)

Shaft Height and Free End Play

TABLE 15

Motor	Normal Shaft Height		Dimension Shaft Height		Free End Play	
					Min.	Max.
4"	1 1/2"	38.1 mm	$\frac{1.508"}{1.498"}$	$\frac{38.30}{38.05}$ mm	0.010" 0.25 mm	0.045" 1.14 mm
6"	2 7/8"	73.0 mm	$\frac{2.875"}{2.869"}$	$\frac{73.02}{72.88}$ mm	0.030" 0.76 mm	0.050" 1.27 mm
8" TYPE 1	4"	101.6 mm	$\frac{4.000"}{3.990"}$	$\frac{101.60}{101.35}$ mm	0.008" 0.20 mm	0.032" 0.81 mm
8" TYPE 2.1	4"	101.6 mm	$\frac{4.000"}{3.990"}$	$\frac{101.60}{101.35}$ mm	0.030" 0.76 mm	0.080" 2.03 mm

If the height, measured from the pump-mounting surface of the motor, is low and/or end play exceeds the limit, the motor thrust bearing is possibly damaged and should be replaced.

Submersible Leads and Cables

A common question is why motor leads are smaller than specified in Franklin's cable charts.

The leads are considered a part of the motor and actually are a connection between the large supply wire and the motor winding. The motor leads are short and there is virtually no voltage drop across the lead.

In addition, the lead assemblies **operate under water**, while at least part of the supply cable must **operate in air**. Lead assemblies running under water operate cooler.

CAUTION: Lead assemblies on submersible motors are suitable only for use in water and may overheat and cause failure if operated in air.



Installation - All Motors

Splicing Submersible Cables

When the drop cable must be spliced or connected to the motor leads, it is necessary that the splice be watertight. This splice can be made with commercially available potting, heat shrink splicing kits, or by careful tape splicing.

Tape splicing should use the following procedure.

- A) Strip individual conductor of insulation only as far as necessary to provide room for a stake type connector. Tubular connectors of the staked type are preferred. If connector outside diameter (OD) is not as large as cable insulation, build up this area with rubber electrical tape.
- B) Tape individual joints with rubber electrical tape, using two layers, with the first layer extending

50.8 mm (two inches) beyond each end of the conductor insulation end, and the second layer extending 50.8 mm (two inches) beyond the ends of the first layer. Wrap tightly, eliminating air spaces as much as possible.

- C) Tape over the rubber electrical tape with #33 Scotch electrical tape, (3M) or equivalent, using two layers as in step "B" and making each layer overlap the end of the preceding layer by at least 50.8 mm (two inches).

In the case of a cable with three conductors encased in a single outer sheath, tape individual conductors as described, staggering joints.

Total thickness of tape should be no less than the thickness of the conductor insulation.

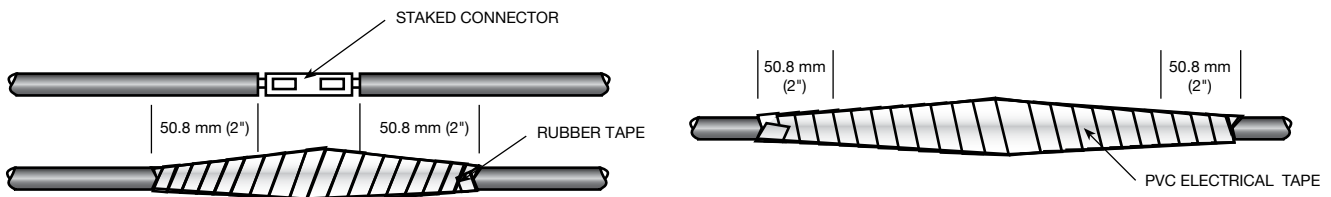

FIG. 12

Heat Shrink Splicing

Pre-place the heat shrinking tubes by sliding them over the individual lead wires using a stake type connector. Once the connection is complete, slide the heat shrink tube over the splice area and center it so that the tube extends between one and two inches beyond each insulated edge of the lead wires.

Use either a heat gun or propane torch with a diffusing tip to evenly distribute heat to the shrinking tubing. Begin applying heat to the middle of the shrink tube, and work outward to avoid trapping air within the tube. Rotate the cable while heating to evenly shrink the tubing. Avoid over heating as this may make tubing brittle. Complete this same process for the remaining lead wires.

In case of a double jacketed lead, heat shrink each individual lead wire, staggering the joints. After all individual lead wires have been prepared with the heat shrink tubing, repeat the process to include a heat shrink tube over the jacket of the cables.

Note: Use only heat shrink tubing with an inner sealant which will melt when heated and ooze out the ends of the tube.

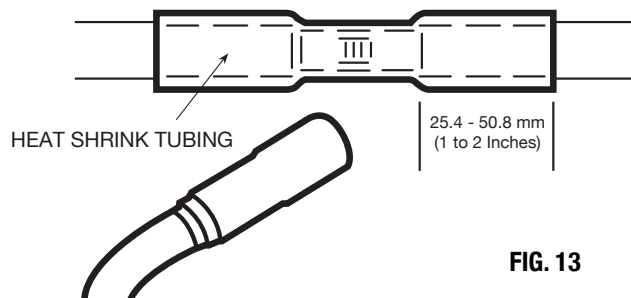

FIG. 13



Maintenance - All Motors

System Troubleshooting

Motor Does Not Start

Possible Cause	Checking Procedures	Corrective Action
A. No power or incorrect voltage.	Check voltage at line terminals The voltage must be $\pm 10\%$ of rated voltage.	Contact power company if voltage is incorrect.
B. Fuses blown or circuit breakers tripped.	Check fuses for recommended size and check for loose, dirty or corroded connections in fuse receptacle. Check for tripped circuit breakers.	Replace with proper fuse or reset circuit breakers.
C. Defective pressure switch.	Check voltage at contact points. Improper contact of switch points can cause voltage less than line voltage.	Replace pressure switch or clean points.
D. Control box malfunction.	For detailed procedure, see pages 34-35.	Repair or replace.
E. Defective wiring	Check for loose or corroded connections or defective wiring.	Correct faulty wiring or connections.
F. Bound pump.	Check for misalignment between pump and motor or a sand bound pump. Amp readings will be 3 to 6 times higher than normal until the overload trips.	Pull pump and correct problem. Run new installation until the water clears.
G. Defective cable or motor.	For detailed procedure, see pages 34-35.	Repair or replace.

Motor Starts Too Often

Possible Cause	Checking Procedures	Corrective Action
A. Pressure switch.	Check setting on pressure switch and examine for defects.	Reset limit or replace switch.
B. Check valve - stuck open.	Damaged or defective check valve will not hold pressure.	Replace if defective.
C. Waterlogged tank.	Check air charge.	Repair or replace.
D. Leak in system.	Check system for leaks.	Replace damaged pipes or repair leaks.



Maintenance - All Motors

System Troubleshooting

Motor Runs Continuously

Possible Cause	Checking Procedures	Corrective Action
A. Pressure switch.	Check switch for welded contacts. Check switch adjustments.	Clean contacts, replace switch, or adjust setting.
B. Low water level in well.	Pump may exceed well capacity. Shut off pump, wait for well to recover. Check static and drawdown level from well head.	Throttle pump output or reset pump to lower level. Do not lower if sand may clog pump.
C. Leak in system.	Check system for leaks.	Replace damaged pipes or repair leaks.
D. Worn pump.	Symptoms of worn pump are similar to those of drop pipe leak or low water level in well. Reduce pressure switch setting, if pump shuts off worn parts may be the fault.	Pull pump and replace worn parts.
E. Loose coupling or broken motor shaft.	Check for loose coupling or damaged shaft.	Replace worn or damaged parts.
F. Pump screen blocked.	Check for clogged intake screen.	Clean screen and reset pump depth.
G. Check valve stuck closed.	Check operation of check valve.	Replace if defective.
H. Control box malfunction.	See pages 36-37 for single-phase.	Repair or replace.

Motor Runs But Overload Protector Trips

Possible Cause	Checking Procedures	Corrective Action
A. Incorrect voltage.	Using voltmeter, check the line terminals. Voltage must be within $\pm 10\%$ of rated voltage.	Contact power company if voltage is incorrect.
B. Overheated protectors.	Direct sunlight or other heat source can raise control box temperature causing protectors to trip. The box must not be hot to touch.	Shade box, provide ventilation or move box away from source.
C. Defective control box.	For detailed procedures, see pages 36-37.	Repair or replace.
D. Defective motor or cable.	For detailed procedures, see pages 34-36.	Repair or replace.
E. Worn pump or motor.	Check running current, see pages 13 & 16-18.	Replace pump and/or motor.



Maintenance - All Motors

TABLE 16 Preliminary Tests - All Sizes Single and Three-Phase

"Test"	Procedure	What it Means
Insulation Resistance	<ol style="list-style-type: none"> 1. Open master breaker and disconnect all leads from control box or pressure switch (QD type control, remove lid) to avoid electric shock hazard and damage to the meter. 2. Set the scale lever to R X 100K and set the ohmmeter on zero. 3. Connect one ohmmeter lead to any one of the motor leads and the other lead to the metal drop pipe. If the drop pipe is plastic, connect the ohmmeter lead to ground. 	<ol style="list-style-type: none"> 1. If the ohms value is normal (Table 17), the motor is not grounded and the cable insulation is not damaged. 2. If the ohms value is below normal, either the windings are grounded or the cable insulation is damaged. Check the cable at the well seal as the insulation is sometimes damaged by being pinched.
Winding Resistance	<ol style="list-style-type: none"> 1. Open master breaker and disconnect all leads from control box or pressure switch (QD type control, remove lid) to avoid electric shock hazard and damage to the meter. 2. Set the scale lever to R X 1 for values under 10 ohms. For values over 10 ohms, set the scale lever to R X 10. "Zero" the ohmmeter. 3. On 3-wire motors measure the resistance of yellow to black (Main winding) and yellow to red (Start winding). On 2-wire motors measure the resistance from line to line. Three-phase motors measure the resistance line to line for all three combinations. 	<ol style="list-style-type: none"> 1. If all ohms values are normal (Tables 7 & 10-12), the motor windings are neither shorted nor open, and the cable colors are correct. 2. If any one value is less than normal, the motor is shorted. 3. If any one ohm value is greater than normal, the winding or the cable is open, or there is a poor cable joint or connection. 4. If some ohms values are greater than normal and some less on single-phase motors, the leads are mixed. See page 36 to verify cable colors.

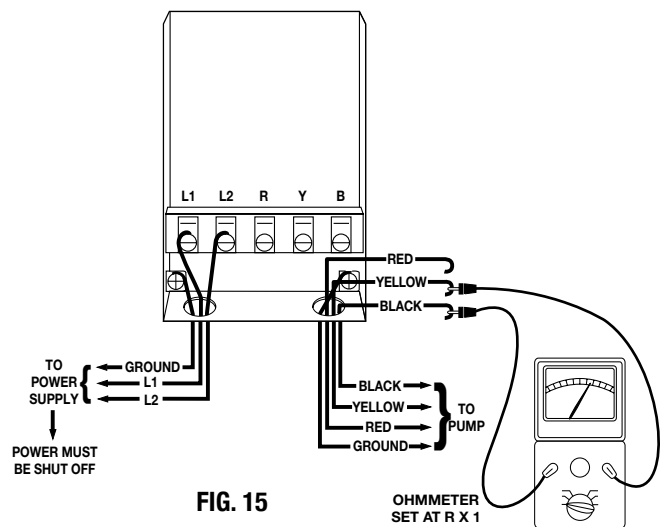
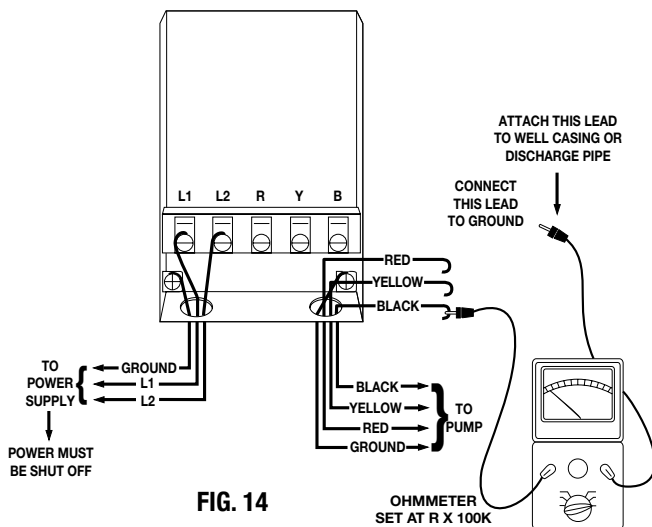



Maintenance - All Motors

Insulation Resistance Readings

TABLE 17 Normal Ohm and Megohm Values Between All Leads and Ground

Condition of Motor and Leads	Ohms Value	MEGOHM Value
A new motor (without drop cable).	200,000,000 (or more)	200 (or more)
A used motor which can be reinstalled in well.	10,000,000 (or more)	10 (or more)
Motor in well. Readings are for drop cable plus motor.		
New motor	2,000,000 (or more)	2.0 (or more)
Motor in good condition.	500,000 - 2,000,000	0.5 - 2.0
Insulation damage, locate and repair	Less than 500,000	Less than .5

Insulation resistance varies very little with rating. Motors of all HP, voltage, and phase rating have similar values of insulation resistance. Table 33 is based on readings taken with a megohm meter with a 500VDC output. Readings may vary using a lower voltage ohmmeter, consult Franklin Electric if readings are in question.

Resistance of Drop Cable (Ohms)

The values below are for copper conductors. If aluminum conductor drop cable is used, the resistance will be higher. To determine the actual resistance of the aluminum drop cable, divide the ohm readings from this chart by 0.61. This chart shows total resistance of cable from control to motor and back.

Winding Resistance Measuring

The winding resistance measured at the motor should fall within the values in tables 7 & 10-12. When measured through the drop cable, the resistance of the drop cable must be subtracted from the ohmmeter readings to get the winding resistance of the motor. See table below.

Drop Cable Resistance

Table 18 DC Resistance in Ohms per 100 ft. of wire (two conductors) @ 10°C

AWG or MCM Wire Size (Copper)	14	12	10	8	6	4	3	2			
Ohms	0.544	0.338	0.214	0.135	0.082	0.052	0.041	0.032			
1	1/0	2/0	3/0	4/0	250	300	350	400	500	600	700
0.026	0.021	0.017	0.013	0.010	0.0088	0.0073	0.0063	0.0056	0.0044	0.0037	0.0032

Drop Cable Resistance

Table 18A DC Resistance in Ohms per 100 meters of wire (two conductors) @ 10°C

Square millimeter (Copper)	1.5	2.5	4	6	10	16		
Ohms	2.630	1.576	0.977	0.651	0.374	0.238		
25	35	50	70	95	120	150	185	240
0.153	0.108	0.075	0.053	0.040	0.031	0.025	0.021	0.016



Maintenance - Single-Phase Motors & Controls

Identification Of Cables When Color Code Is Unknown (Single-Phase 3-Wire Units)

If the colors on the individual drop cables cannot be found with an ohmmeter, measure:

- Cable 1 to Cable 2
- Cable 2 to Cable 3
- Cable 3 to Cable 1

Find the highest resistance reading.

The lead not used in the highest reading is the yellow lead.

Use the yellow lead and each of the other two leads to get two readings:

- Highest is the red lead.
- Lowest is the black lead.

EXAMPLE:

The ohmmeter readings were:

- Cable 1 to Cable 2—6 ohms
- Cable 2 to Cable 3—2 ohms
- Cable 3 to Cable 1— 4 ohms

The lead not used in the highest reading (6 ohms) was
Cable 3—Yellow

From the yellow lead, the highest reading (4 ohms) was
To Cable 1—Red

From the yellow lead, the lowest reading (2 ohms) was
To Cable 2—Black

Single-Phase Control Boxes

Checking and Repairing Procedures (Power On)

WARNING: Power must be on for these tests. Do not touch any live parts.

A. VOLTAGE MEASUREMENTS

Step 1. Motor Off

1. Measure voltage at L1 and L2 of pressure switch or line contactor.
2. Voltage Reading: Should be $\pm 10\%$ of motor rating.

Step 2. Motor Running

1. Measure voltage at load side of pressure switch or line contactor with pump running.
2. Voltage Reading: Should remain the same except for slight dip on starting. Excessive voltage drop can be caused by loose connections, bad contacts, ground faults, or inadequate power supply.
3. Relay chatter is caused by low voltage or ground faults.

B. CURRENT (AMP) MEASUREMENTS

1. Measure current on all motor leads.
2. Amp Reading: Current in red lead should momentarily be high, then drop within one second to values on page 13. This verifies relay operation. Current in black and yellow leads should not exceed values on page 13.
3. Relay failures will cause red lead current to remain high and overload tripping.
4. Open run capacitor(s) will cause amps to be higher than normal in the black and yellow motor leads and lower than normal in the red motor lead.
5. A bound pump will cause locked rotor amps and overload tripping.
6. Low amps may be caused by pump running at shutoff, worn pump, or stripped splines.
7. Failed start capacitor or open relay are indicated if the red lead current is not momentarily high at starting.

CAUTION: The tests in this manual for components such as capacitors, and relays should be regarded as indicative and not as conclusive. For example, a capacitor may test good (not open, not shorted) but may have lost some of its capacitance and may no longer be able to perform its function.

To verify proper operation of relays, refer to operational test procedure described above in Section B-2.



Maintenance - Single-Phase Motors & Controls

Ohmmeter Tests

QD Control Box (Power Off)

A. START CAPACITOR

1. Meter Setting: R x 1,000.
2. Connections: Capacitor terminals.
3. Correct meter reading: Pointer should swing toward zero, then back to infinity.

B. POTENTIAL (VOLTAGE) RELAY

Step 1. Coil Test

1. Meter setting: R x 1,000.

2. Connections: #2 & #5.

3. Correct meter readings:

For 220-240 Volt Boxes
4.5-7.0 (4,500 to 7,000 ohms).

Step 2. Contact Test

1. Meter setting: R x 1.
2. Connections: #1 & #2.
3. Correct meter reading: Zero for all models.

Ohmmeter Tests

Integral Horsepower Control Box (Power Off)

A. OVERLOADS (Push Reset Buttons to make sure contacts are closed.)

1. Meter Setting: R x 1.
2. Connections: Overload terminals.
3. Correct meter reading: Less than 0.5 ohms.

B. CAPACITOR (Disconnect leads from one side of each capacitor before checking.)

1. Meter Setting: R x 1,000.
2. Connections: Capacitor terminals.
3. Correct meter reading: Pointer should swing toward zero, then drift back to infinity, except for capacitors with resistors which will drift back to 15,000 ohms.

C. RELAY COIL (Disconnect lead from Terminal #5)

1. Meter Setting: R x 1,000.
2. Connections: #2 & #5.
3. Correct meter readings: 4.5-7.0 (4,500 to 7,000 ohms) for all models.

D. RELAY CONTACT (Disconnect lead from Terminal #1)

1. Meter Setting: R x 1.
2. Connections: #1 & #2.
3. Correct meter reading: Zero ohms for all models.

CAUTION: The tests in this manual for components such as capacitors, and relays should be regarded as indicative and not as conclusive. For example, a capacitor may test good (not open, not shorted) but may have lost some of its capacitance and may no longer be able to perform its function.

To verify proper operation of relays, refer to operational test procedure described on page 36, Section B-2.



Maintenance - Single-Phase Motors & Controls

QD Control Box Parts List

TABLE 19 Q.D. Control Box Components 50Hz.

Model	KW	HP	Volts	Relay	Capacitor	Capacitor Rating	Capacitor-Overload Asm.	Overload
2803530115	0.25	1/3	220	155031112	275461123	43-53 Mfd. 220v	151033957	155250101
2803550115	0.37	1/2	220	155031112	275461123	43-53 Mfd. 220v	151033957	155250101
2803570115	0.55	3/4	220	155031112	275461108	59-71 Mfd. 220v	151033906	155250102
2803580115	0.75	1	220	155031112	275461106	86-103 Mfd. 220v	151033918	155250103

Same parts are used on Suffix 101 Control Boxes.

The replacement kit for relay 155031112 is 305213912.

Table 19A Capacitor Replacement Kit

Capacitor	Kit
275461106	305205906
275461108	305205908
275461123	305205923

Table 19B Cap/Overload asm. replacement Kit

Assembly	Kit
151033906	305218906
151033918	305218918
151033957	305218957

Integral HP Control Box Parts List

TABLE 20 Control Box Components, 1.1 KW and larger 50Hz.

Model	KW	HP	Volts	Relay (1)	Start	Run	Overloads
2823508110	1.1	1 1/2	220	155031112	One 275464113 105-126 Mfd. 220v	One 155328102 10 Mfd. 370v	275411114
2823518110	1.5	2	220	155031112	One 275468115 189-227 Mfd. 220v	One 155328103 20 Mfd. 370v	275411102 run, 275411106 start
2823528110	2.2	3	220	155031112	One 275468119 270-324 Mfd. 220v	One 155327102 35 Mfd. 370v	275406107 run, 275411117 start
2822539010	3.7	5	220	155031112	Two 275468115 189-227 Mfd. 220v	One 155327101 30 Mfd. 220v One 155327109 45 Mfd. 220v	275406102 run, 275411102 start

(1) Relay Replacement Kit 305213912

20A Capacitor Replacement Kit

Capacitor	Kit
155327101	305203901
155327102	305203902
155327109	305203909
155328102	305204902
275464113	305207913
275468115	305208915
275468119	305208919

20B Overload Replacement Kit

Capacitor	Kit
275406102	305214902
275406107	305214907
275411102	305215902
275411106	305215906
275411117	305215917
275411114	305215914



Maintenance - Single-Phase Motors & Controls

Control Box Wiring Diagrams

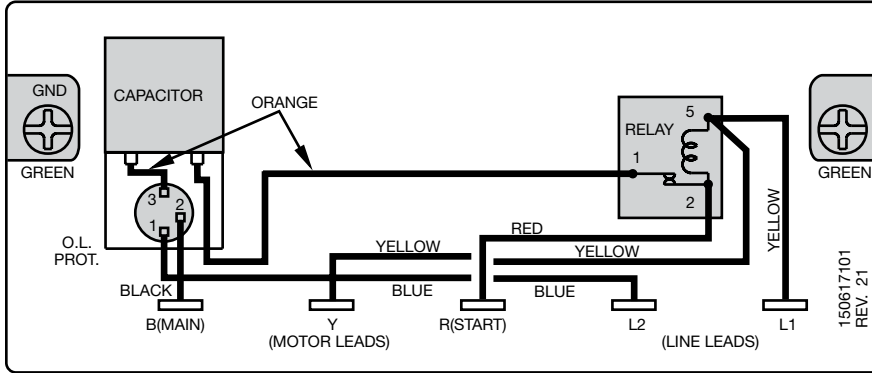

1/3 - 1 HP 4"
280 35_ 0115

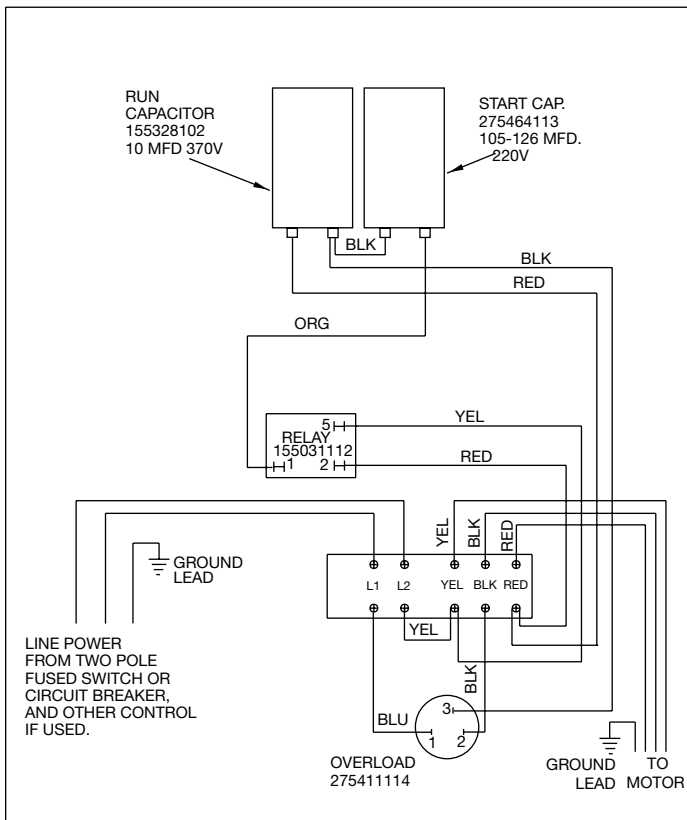

1 1/2 HP
282 350 8110



Maintenance - Single-Phase Motors & Controls

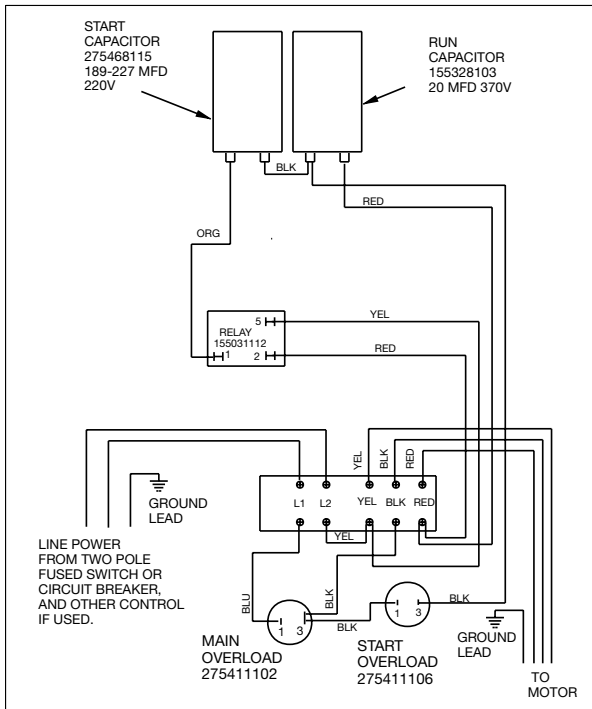

2 HP
282 351 8110

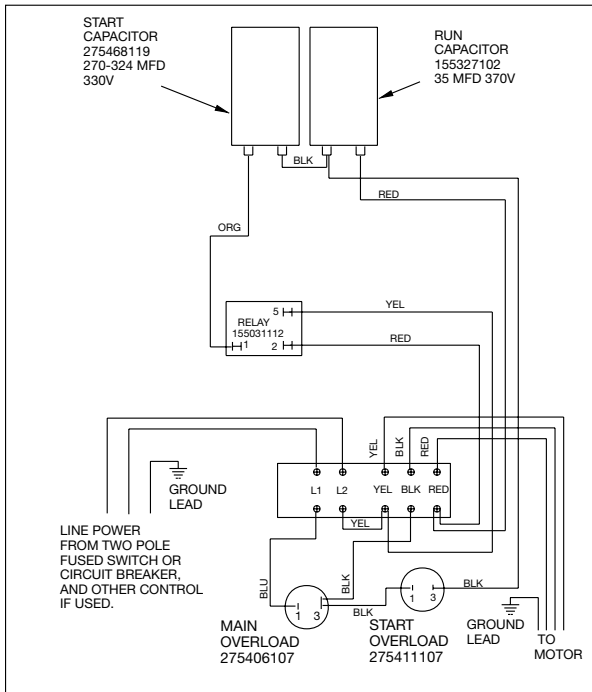

3 HP
282 352 8110

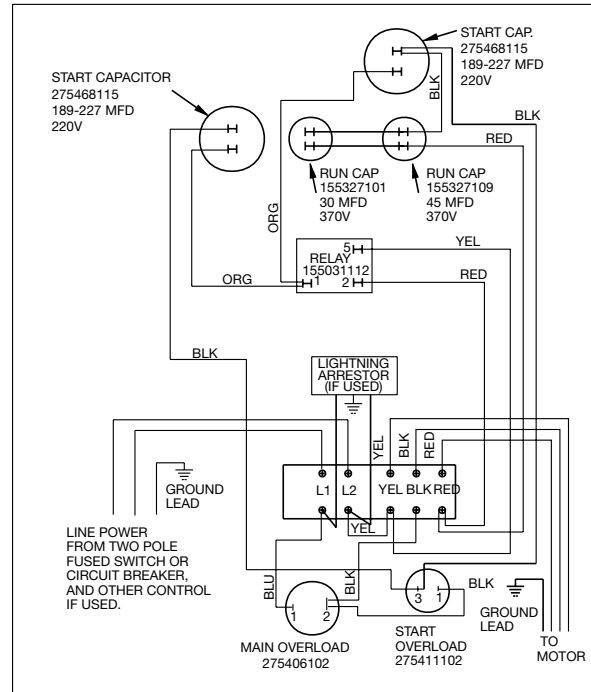

5 HP
282 353 9010



Maintenance - Electronic Products

Pumptec

Pumptec is a load sensing device that monitors the load on submersible pump/motors. If the load drops below a preset level for a minimum of 4 seconds the Pumptec will shut off the motor.

The Pumptec is designed for use on Franklin Electric 2- and 3-wire motors (1/3 to 1 1/2 HP) 220V. The Pumptec is not designed for jet pumps.

Symptom	Checks or Solution
Pumptec trips in about 4 sec. with some water delivery.	<ul style="list-style-type: none"> A. Is the voltage more than 90% of nameplate rating? B. Are the pump and motor correctly matched? C. Is the Pumptec wired correctly? Check the wiring diagram and pay special attention to the positioning of the power lead.
Pumptec trips in about 4 sec. with no water delivery.	<ul style="list-style-type: none"> A. The pump may be airlocked. If there is a check valve on top of the pump, put another section of pipe between the pump and the check valve. B. The pump may be out of water. C. Check the valve settings. The pump may be dead-heading. D. Pump or motor shaft may be broken. E. Motor overload may be tripped. Check the motor current (amperage).
Pumptec will not time-out and reset.	<ul style="list-style-type: none"> A. Check switch position on the side of the circuit board in Pumptec. Make sure the switch is not set between settings. B. If the reset time switch is set to manual reset (position 0), Pumptec will not reset. (Turn power off for 5 sec., then back on to reset.)
The pump/motor will not run at all.	<ul style="list-style-type: none"> A. Check voltage. B. Check wiring. C. Bypass Pumptec by connecting L2 and the motor lead with a jumper. If motor does not run, the problem is not Pumptec. D. Check that Pumptec is installed between the control switch and motor.
Pumptec will not trip when the pump breaks suction.	<ul style="list-style-type: none"> A. Be sure you have a Franklin motor. B. Check wiring connections. Is power lead connected to the correct terminal? Is motor lead connected to correct terminal? C. Check for ground fault in the motor and excessive friction in the pump. D. The well may be "gulping" enough water to keep Pumptec from tripping. It may be necessary to adjust Pumptec for these extreme applications. Call the Franklin Electric Submersible Service Hotline at 800-348-2420 for information. E. Does the control box have a run capacitor? If so, Pumptec will not trip (except with Franklin 1 1/2 HP motors).
Pumptec chatters when running.	<ul style="list-style-type: none"> A. Check for low voltage. B. Check for water logged tank. Rapid cycling for any reason can cause the Pumptec relay to chatter. C. Make sure the L2 and motor wires are installed correctly. If they are reversed, the unit can chatter.



Maintenance - Electronic Products

Pumptec-Plus

Pumptec-Plus is a pump/motor protection device designed to work on any 220V single-phase induction motor (PSC, CSCR, CSIR, and split-phase) ranging in size from 1/2 to 5 horsepower. Pumptec-Plus uses a micro-computer to continuously monitor motor power and line voltage to provide protection against dry well, water logged tank, high and low voltage and mud or sand clogging.

Pumptec-Plus - Trouble During Installation

Symptom	Possible Cause	Solution
Unit Appears Dead (No Lights)	No Power to Unit	Check wiring. Power supply voltage should be applied to L1 and L2 terminals of the Pumptec-Plus. In some installations the pressure switch or other control device is wired to the input of the Pumptec-Plus. Make sure this switch is closed.
Flashing Yellow Light	Unit Needs To Be Calibrated	Pumptec-Plus is calibrated at the factory so that it will overload on most pump systems when the unit is first installed. This overload condition is a reminder that the Pumptec-Plus unit requires calibration before use. See step 7 of the installation instructions.
	Miscalibrated	Pumptec-Plus should be calibrated on a full recovery well with the maximum water flow. Flow restrictors are not recommended.
Flashing Yellow Light During Calibration	Two Wire Motor	Step C of the calibration instructions indicate that a flashing green light condition will occur 2 to 3 seconds after taking the SNAPSHOT of the motor load. On some two-wire motors the yellow light will flash instead of the green light. Press and release the reset button. The green should start flashing.
Flashing Red and Yellow Lights	Power Interruption	During the installation of Pumptec-Plus power may be switched on and off several times. If power is cycled more than four times within a minute Pumptec-Plus will trip on rapid cycle. Press and release the reset button to restart the unit.
	Float Switch	A bobbing float switch may cause the unit to detect a rapid cycle condition on any motor or an overload condition on two wire motors. Try to reduce water splashing or use a different switch.
Flashing Red Light	High Line Voltage	The line voltage is over 242 volts. Check line voltage. Report high line voltage to the power company.
	Unloaded Generator	If you are using a generator the line voltage may become too high when the generator unloads. Pumptec-Plus will not allow the motor to turn on again until the line voltage returns to normal. Over voltage trips will also occur if line frequency drops too far below 50 Hz.
Solid Red Light	Low Line Voltage	The line voltage is below 198 volts. Check line voltage.
	Loose Connections	Check for loose connections which may cause voltage drops.
	Loaded Generator	If you are using a generator the line voltage may become too low when the generator loads. Pumptec-Plus will trip on undervoltage if the generator voltage drops below 198 volts for more than 2.5 seconds. Undervoltage trips will also occur if the line frequency rises too far above 50 Hz.



Maintenance - Electronic Products

Pumptec-Plus

Pumptec-Plus - Troubleshooting After Installation

Symptom	Possible Cause	Solution
Solid Yellow Light	Dry Well	Wait for the automatic restart timer to time out. During the time out period, the well should recover and fill with water. If the automatic reset timer is set to the manual position, then the reset button must be pressed to reactivate the unit.
	Blocked Intake	Clear or replace pump intake screen.
	Blocked Discharge	Remove blockage in plumbing.
	Check Valve Stuck	Replace check valve.
	Broken Shaft	Replace broken parts.
	Severe Rapid Cycling	Machine gun rapid cycling can cause an underload condition. See flashing red and yellow lights section below.
	Worn Pump	Replace worn pump parts and recalibrate.
Yellow Flashing Light	Stalled Motor	Repair or replace motor. Pump may be sand or mud locked.
	Float Switch	A bobbing float switch can cause two-wire motors to stall. Arrange plumbing to avoid splashing water. Replace float switch.
	Ground Fault	Check insulation resistance on motor and control box cable.
Solid Red Light	Low Line Voltage	The line voltage is below 198 volts. Pumptec-Plus will try to restart the motor every two minutes until line voltage is normal.
	Loose Connections	Check for excessive voltage drops in the system electrical connections (i.e. circuit breakers, fuse clips, pressure switch, and Pumptec-Plus L1 and L2 terminals). Repair connections.
Flashing Red Light	High Line Voltage	The line voltage is over 242 volts. Check line voltage. Report high line voltage to the power company.
Flashing Red and Yellow Lights	Rapid Cycle	The most common cause for the rapid cycle condition is a waterlogged tank. Check for a ruptured bladder in the water tank. Check the air volume control or snifter valve for proper operation. Check setting on the pressure switch and examine for defects.
	Leaky Well System	Replace damaged pipes or repair leaks.
	Stuck Check Valve	Failed valve will not hold pressure. Replace valve.
	Float Switch	Press and release the reset button to restart the unit. A bobbing float switch may cause the unit to detect a rapid cycle condition on any motor or an overload condition on two wire motors. Try to reduce water splashing or use a different switch.



Maintenance - Electronic Products

SubDrive2W, 75, 100, 150, & 300

SubDrive Troubleshooting

Should an application or system problem occur, built-in diagnostics will protect the system. The “FAULT” light or digital display on the front of the SubDrive Controller will flash a given number of times or display a number indicating the nature of the fault. In some cases, the system will shut itself off until corrective action is taken. Fault codes and their corrective actions are listed below. See SubDrive Installation Manual for installation data.

Number Of Flashes Or Digital Display	Fault	Possible Cause	Corrective Action
1	Motor Underload	<ul style="list-style-type: none"> - Overpumped well - Broken shaft or coupling - Blocked screen, worn pump - Air/gas locked pump - SubDrive not set properly for pump end 	<ul style="list-style-type: none"> - Frequency near maximum with less than 65% of expected load, 42% if DIP #3 is “on” - System is drawing down to pump inlet (out of water) - High static, light loading pump - reset DIP switch #3 to “on” for less sensitivity if not out of water - Check pump rotation (SubDrive only) reconnect if necessary for proper rotation - Air/gas locked pump - if possible, set deeper in well to reduce - Verify DIP switches are set properly
2	Undervoltage	<ul style="list-style-type: none"> - Low line voltage - Misconnected input leads 	<ul style="list-style-type: none"> - Line voltage low, less than approximately 150 VAC (normal operating range = 190 to 260 VAC) - Check incoming power connections and correct or tighten if necessary - Correct incoming voltage - check circuit breaker or fuses, contact power company
3	Locked Pump	<ul style="list-style-type: none"> - Motor and/or pump misalignment - Dragging motor and/or pump - Abrasives in pump 	<ul style="list-style-type: none"> - Amperage above SFL at 10 Hz - Remove and repair or replace as required
4	Incorrectly Wired	<ul style="list-style-type: none"> - MonoDrive only - Wrong resistance values on main and start 	<ul style="list-style-type: none"> - Wrong resistance on DC test at start - Check wiring, check motor size and DIP switch setting, adjust or repair as needed
5	Open Circuit	<ul style="list-style-type: none"> - Loose connection - Defective motor or drop cable - Wrong motor 	<ul style="list-style-type: none"> - Open reading on DC test at start. - Check drop cable and motor resistance, tighten output connections, repair or replace as necessary, use “dry” motor to check drive functions, if drive will not run and exhibits underload fault replace drive
6	Short Circuit	<ul style="list-style-type: none"> - When fault is indicated immediately after power-up, short circuit due to loose connection, defective cable, splice or motor 	<ul style="list-style-type: none"> - Amperage exceeded 50 amps on DC test at start or max amps during running - Incorrect output wiring, phase to phase short, phase to ground short in wiring or motor - If fault is present after resetting and removing motor leads, replace drive
	Over Current	<ul style="list-style-type: none"> - When fault is indicated while motor is running, over current due to loose debris trapped in pump 	<ul style="list-style-type: none"> - Check pump
7	Overheated Drive	<ul style="list-style-type: none"> - High ambient temperature - Direct sunlight - Obstruction of airflow 	<ul style="list-style-type: none"> - Drive heat sink has exceeded max rated temperature, needs to drop below 85 °C to restart - Fan blocked or inoperable, ambient above 125 °F, direct sunlight, air flow blocked - Replace fan or relocate drive as necessary
8 (SubDrive300 only)	Over Pressure	<ul style="list-style-type: none"> - Improper pre-charge - Valve closing too fast - Pressure setting too close to relief valve rating 	<ul style="list-style-type: none"> - Reset the pre-charge pressure to 70% of sensor setting. Reduce pressure setting well below relief valve rating. Use next size larger pressure tank. - Verify valve operation is within manufacturer’s specifications. - Reduce system pressure setting to a value less than pressure relief rating.
RAPID	Internal Fault	<ul style="list-style-type: none"> - A fault was found internal to drive 	<ul style="list-style-type: none"> - Unit may require replacement. Contact your supplier.
9 (SubDrive2W only)	Over Range (Values Outside Normal Operating Range)	<ul style="list-style-type: none"> - Wrong hp/voltage - Internal fault 	<ul style="list-style-type: none"> - Verify motor hp and voltage - Unit may require replacement. Contact your supplier.



Maintenance - Electronic Products

SubMonitor

SubMonitor Troubleshooting

Fault Message	Problem/Condition	Possible Cause
SF Amps Set Too High	SF Amps setting above 359 Amps.	Motor SF Amps not entered.
Phase Reversal	Reversed incoming voltage phase sequence.	Incoming power problem.
Underload	Normal line current.	Wrong SF Max Amps setting.
	Low line current.	Over pumping well. Clogged pump intake. Closed valve. Loose pump impeller. Broken shaft or coupling. Phase loss.
Overload	Normal line current.	Wrong SF Max Amps setting.
	High line current.	High or low line voltage. Ground fault. Pump or motor dragging. Motor stalled or bound pump.
Overheat	Motor temperature sensor has detected excess motor temperature.	High or low line voltage. Motor is overloaded. Excessive current unbalance. Poor motor cooling. High water temperature. Excessive electrical noise (VFD in close proximity).
Unbalance	Current difference between any two legs exceeds programmed setting.	Phase loss. Unbalanced power supply. Open Delta transformer.
Overvoltage	Line voltage exceeds programmed setting.	Unstable power supply.
Undervoltage	Line voltage below programmed setting.	Poor connection in motor power circuit. Unstable or weak power supply.
False Starts	Power has been interrupted too many times in a 10 second period.	Chattering contacts. Loose connections in motor power circuit. Arcing contacts.



Maintenance - Electronic Products

Subtrol-Plus (Obsolete - See SubMonitor)

Subtrol-Plus - Troubleshooting After Installation

Symptom	Possible Cause or Solution
Subtrol-Plus Dead	When the Subtrol-Plus reset button is depressed and released, all indicator lights should flash. If line voltage is correct at the Subtrol-Plus L1, L2, L3 terminals and the reset button does not cause lights to flash, Subtrol-Plus receiver is malfunctioning.
Green Off Time Light Flashes	The green light will flash and not allow operation unless both sensor coils are plugged into the receiver. If both are properly connected and it still flashes, the sensor coil or the receiver is faulty. An ohmmeter check between the two center terminals of each sensor coil connected should read less than 1 ohm, or coil is faulty. If both coils check good, receiver is faulty.
Green Off Time Light On	The green light is on and the Subtrol-Plus requires the specified off time before the pump can be restarted after having been turned off. If the green light is on except as described, the receiver is faulty. Note that a power interruption when the motor is running will initiate the delay function.
Overheat Light On	This is a normal protective function which turns off the pump when the motor reaches maximum safe temperatures. Check that amps are within the nameplate maximum on all three lines, and that the motor has proper water flow past it. If overheat trip occurs without apparent motor overheating, it may be the result of an arcing connection somewhere in the circuit or extreme noise interference on the power lines. Check with the power company or Franklin Electric. A true motor overheat trip will require at least five minutes for a motor started cold. If trips do not conform to this characteristic, suspect arcing connections, power line noise, ground fault, or SCR variable speed control equipment.
Overload Light On	This is a normal protective function, protecting against an overload or locked pump. Check the amps in all lines through a complete pumping cycle, and monitor whether low or unbalanced voltage may be causing high amps at particular times. If overload trip occurs without high amps, it may be caused by a faulty rating insert, receiver, or sensor coil. Recheck that the insert rating matches the motor. If it is correct, carefully remove it from the receiver by alternately lifting sides with a knife blade or thin screwdriver, and make sure it has no pins bent over. If the insert is correct and its pins are okay, replace receiver and/or sensor coils.
Underload Light On	This is a normal protective function. A. Make sure the rating insert is correct for the motor. B. Adjusting the underload setting as described to allow the desired range of operating conditions. Note that a DECREASE in underload setting is required to allow loading without trip. C. Check for drop in amps and delivery just before trip, indicating pump breaking suction, and for unbalanced line current. D. With the power turned off, recheck motor lead resistance to ground. A grounded lead can cause underload trip.



Maintenance - Electronic Products

Subtrol-Plus (Obsolete - See SubMonitor)

Subtrol-Plus - Troubleshooting After Installation (Continued)

Symptom	Possible Cause or Solution
Tripped Light On	Whenever the pump is off as a result of Subtrol-Plus protective function, the red tripped light is on. A steady light indicates the Subtrol-Plus will automatically allow the pump to restart as described, and a flashing light indicates repeated trips, requiring manual reset before the pump can be restarted. Any other red light operation indicates a faulty receiver. One-half voltage on 460 V will cause tripped light on.
Control Circuit Fuse Blows	With power turned off, check for a shorted contactor coil or a grounded control circuit lead. The coil resistance should be at least 10 ohms and the circuit resistance to panel frame over 1 megohm. A standard or delay-type 2 amp fuse should be used.
Contactor Will Not Close	<p>If proper voltage is at the control coil terminals when controls are operated to turn the pump on, but the contactor does not close, turn off power and replace the coil. If there is no voltage at the coil, trace the control circuit to determine if the fault is in the Subtrol-Plus receiver, fuse, wiring, or panel operating switches. This tracing can be done by first connecting a voltmeter at the coil terminals, and then moving the meter connections step by step along each circuit to the power source, to determine at which component the voltage is lost.</p> <p>With the Subtrol-Plus receiver powered up, with all leads disconnected from the control terminals and with an ohmmeter set at RX10, measure the resistance between the control terminals. It should measure 100 to 400 ohms. Depress and hold in the reset button. The resistance between the control terminals should measure close to infinity.</p>
Contactor Hums or Chatters	Check that coil voltage is within 10% of rated voltage. If voltage is correct and matches line voltage, turn off power and remove the contactor magnetic assembly and check for wear, corrosion, and dirt. If voltage is erratic or lower than line voltage, trace the control circuit for faults similar to the previous item, but looking for a major drop in voltage rather than its complete loss.
Contactor Opens When Start Switch is Released	Check that the small interlocks switch on the side of the contactor closes when the contactor closes. If the switch or circuit is open, the contactor will not stay closed when the selector switch is in HAND position.
Contactor Closes But Motor Doesn't Run	Turn off power. Check the contactor contacts for dirt, corrosion, and proper closing when the contactor is closed by hand.
Signal Circuit Terminals Do Not Energize	With the Subtrol-Plus receiver powered up and all leads disconnected from the signal terminals, with an Ohmmeter set at RX10, measure the resistance between the signal terminals. Resistance should measure close to infinite. Depress and hold in the reset button. The resistance between the signal terminals should measure 100 to 400 ohms.



Abbreviations

A	Amp or amperage	MCM	Thousand Circular Mills
AWG	American Wire Gauge	mm	Millimeter
BJT	Bipolar Junction Transistor	MOV	Metal Oxide Varister
°C	Degree Celsius	NEC	National Electrical Code
CB	Control Box	NEMA	National Electrical Manufacturer Association
CRC	Capacitor Run Control	Nm	Newton Meter
DI	Deionized	NPSH	Net Positive Suction Head
Dv/dt	Rise Time of the Voltage	OD	Outside Diameter
EFF	Efficiency	OL	Overload
°F	Degree Fahrenheit	PF	Power Factor
FDA	Food & Drug Administration	psi	Pounds per Square Inch
FL	Full Load	PWM	Pulse Width Modulation
ft	Foot	QD	Quick Disconnect
ft-lb	Foot Pound	R	Resistance
ft/s	Feet per Second	RMA	Return Material Authorization
GFCI	Ground Fault Circuit Interrupter	RMS	Root Mean Squared
gpm	Gallon per Minute	rpm	Revolutions per Minute
HERO	High Efficiency Reverse Osmosis	SF	Service Factor
hp	Horsepower	SFhp	Service Factor Horsepower
Hz	Hertz	S/N	Serial Number
ID	Inside Diameter	TDH	Total Dynamic Head
IGBT	Insulated Gate Bipolar Transistor	UNF	Fine Thread
in	Inch	V	Voltage
kVA	Kilovolt Amp	VAC	Voltage Alternating Current
kVAR	Kilovolt Amp Rating	VDC	Voltage Direct Current
kW	Kilowatt (1000 watts)	VFD	Variable Frequency Drive
L1, L2, L3	Line One, Line Two, Line Three	W	Watts
lb-ft	Pound Feet	XFMR	Transformer
L/min	Liter per Minute	Y-D	Wye-Delta
mA	Milliamp	Ω	ohms
max	Maximum		





Notes
